



Istruzioni per l'uso

Instructions for use

Instructions d'utilisation

Gebrauchsanweisung

Instrucciones de uso

CONTAMETRI
CHAIN COUNTER
COMPTEUR MÉTRIQUE
METERZÄHLER
CUENTAMETROS
EV-011



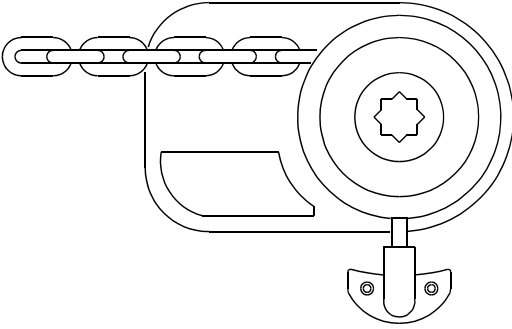

Fig. 1A

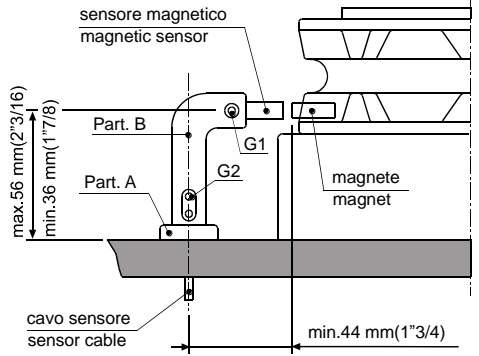

Fig. 1B

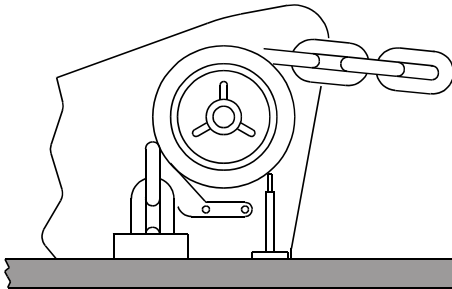

Fig. 2A

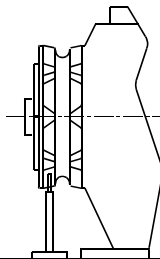

Fig. 2B

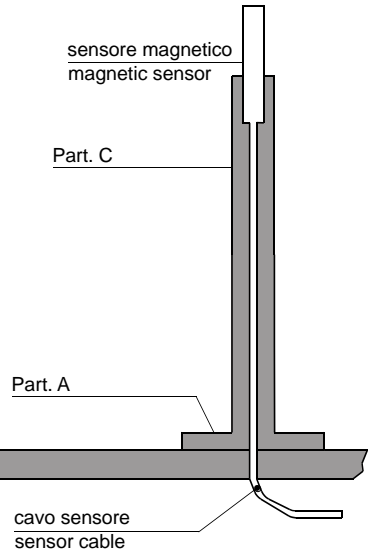

Fig. 2C

Descrizione

Il contametri EV-011 permette la visualizzazione dei metri o piedi di catena svolta da un salpa ancora.



Lo strumento non dispone della funzione di comando del verricello: i pulsanti Up e Down servono solamente per l'impostazione dello strumento.

Dati tecnici

Tensione di alimentazione	da 10 a 30 V DC
Assorbimento di corrente	max 20 mA
Grado di protezione involucro parte frontale	IP65*
Temperatura operativa	0 / +70 °C (32 / 158 °F)
Altezza caratteri <i>display</i>	9 mm
Misura massima raggiungibile	999 metri – 999 piedi
Dimensioni (mm)	60 x 60 x 18
Peso (g)	55

* esclusa la zona di connessione dei cavi



Attenzione

ALIMENTARE ESCLUSIVAMENTE IN CORRENTE CONTINUA.

Note generali

Il contametri EV-011 deve essere utilizzato per gli scopi descritti in questo manuale - visualizzazione dei metri/piedi di catena svolti da un salpa ancora. Qualunque altro utilizzo è da ritenersi un uso improprio.

La manomissione dello strumento provoca il decadimento immediato della garanzia.

Componenti

La confezione contiene:

- contometri, guarnizione, coperchio di chiusura e 2 viti di fissaggio;
- connettore maschio a 6 poli con 6 contatti maschio a crimpare;
- istruzioni per l'uso.

Installazione

Installazione del magnete sul salpa ancora

- Il foro da praticare su un dente del barbotin - del diametro di 6,5 mm (~1/4") e della profondità di 8 mm (5/16") - deve trovarsi in una zona non interessata dal passaggio della catena.
- Per i salpa ancora ad asse verticale (vedi Fig. 1B) eseguire la foratura nella circonferenza inferiore del barbotin.
- Per i salpa ancora ad asse orizzontale (vedi Fig. 2B) eseguire la foratura sulla circonferenza esterna del barbotin.
- Verificare, inoltre, che la parte sporgente del magnete, durante la rotazione del barbotin, non urti contro la base o il sensore.
- Inserire il magnete, nel foro, dalla parte metallica lasciando sporgere la parte protetta di circa 2 mm. Fissarlo utilizzando un collante per metalli (colla epossidica bi-componente) o silicone. Il collante utilizzato deve essere resistente all'ambiente marino.

Montaggio sensore magnetico per salpa ancora ad asse verticale

(vedi Fig. 1A – 1B)

- Praticare nella coperta un foro del diametro di 4 mm (~3/16") per il passaggio del cavo del sensore.
- Fissare il Part. A del supporto, con le due viti a corredo, dopo avere posizionato nella parte inferiore dello stesso la guarnizione OR.
- Inserire il Part. B, con il sensore magnetico, sul supporto A e regolarlo in altezza in modo che si trovi in asse con il magnete fissato sul barbotin.
- Avvicinare il sensore a circa 3 mm (~1/8") dal magnete e fissarlo serrando la vite G1. Serrare successivamente la vite G2.

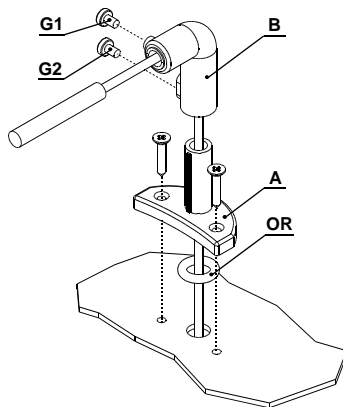

Montaggio sensore magnetico per salpa ancora ad asse orizzontale

(vedi Fig. 2A – 2B – 2C)

- Praticare nella coperta un foro del diametro di 4 mm (~3/16") per il passaggio del cavo del sensore.
- Fissare il Part. A del supporto, con le due viti a corredo, dopo avere posizionato nella parte inferiore dello stesso la guarnizione OR.
- Tagliare, con un seghetto, a misura il Part. C. Il sensore deve essere posizionato a circa 3 mm (~1/8") dal magnete.
- Inserire il Part. C, con il sensore magnetico, sul supporto A e fissarlo utilizzando un collante per materiali plastici (colla epossidica bi-componente) o silicone.
- Fissare, con lo stesso collante, il sensore al Part. C.

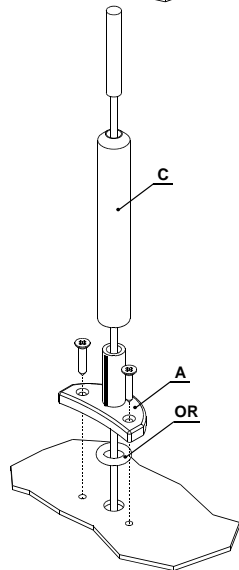

Installazione contametri

(vedi schema elettrico)



Attenzione

STACCARE SEMPRE LA BATTERIA PRIMA DI PROCEDERE ALL'INSTALLAZIONE.

- Il contametri deve essere posizionato in modo che il *display* sia facilmente leggibile e non esposto ai raggi solari.
- La parte posteriore del contametri deve essere protetta dal contatto di acqua o di umidità.
- Lo strumento può essere fissato su plance con spessore superiore a 6 mm (~1/4"). Per il fissaggio utilizzare viti M3 x 5 per plance da 6 mm (~1/4"). Per spessori maggiori utilizzare viti M3 con lunghezza inferiore di 2/3 mm (~1/8") dello spessore della plancia.
- Nella parte posteriore, alla plancia, vi deve essere uno spazio minimo pari a 35 mm. Inoltre, deve essere presente un accesso per l'installazione e la manutenzione.
- Praticare un foro del diametro di 24 mm (~1") – max. 30 mm (~1" 3/16) – sulla plancia e 2 fori da 9 mm (~7/16") per le viti di fissaggio del contametri (vedi figura). Tagliare con un tronchese i tre piolini posti sul lato posteriore dello strumento, posizionare il contametri e fissarlo alla plancia serrando le due viti. Qualora sulla plancia sia già presente un foro da 54 mm (2" 1/8) non occorre tagliare i piolini posteriori.

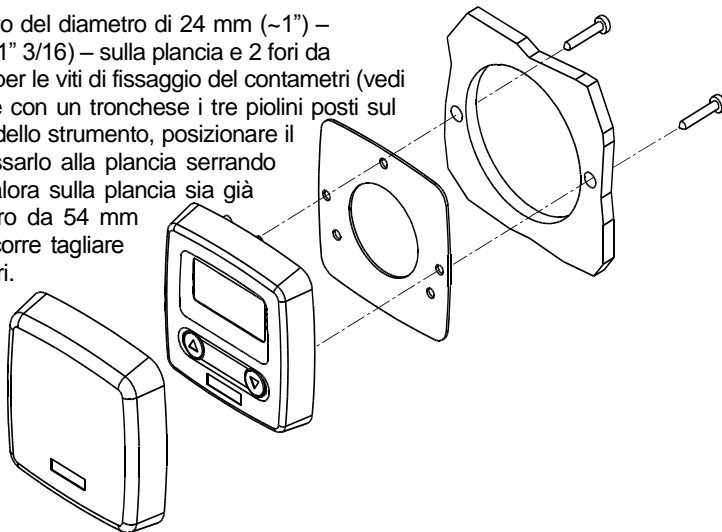

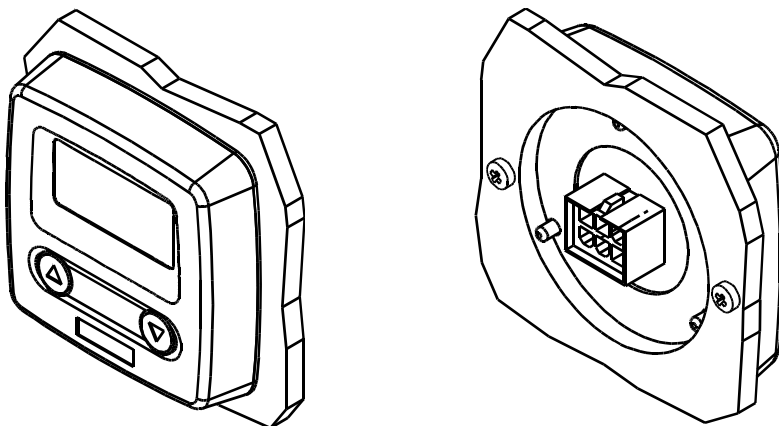

- La guarnizione deve essere interposta tra il contametri e la plancia.
- Per il collegamento elettrico seguire le indicazioni dello schema allegato. I cavi devono avere una sezione minima di 1,5 mm². Non utilizzare per l'alimentazione la tensione proveniente dal gruppo batterie motori.
- Montare un fusibile di protezione da 0,5 A (ampere) sul cavo + della batteria.
- Lo strumento risponde agli standard EMC (EN55022) e deve essere posizionato a una distanza di 0,5 metri (1,64 Ft) da apparecchi radio riceventi.

Collegamenti

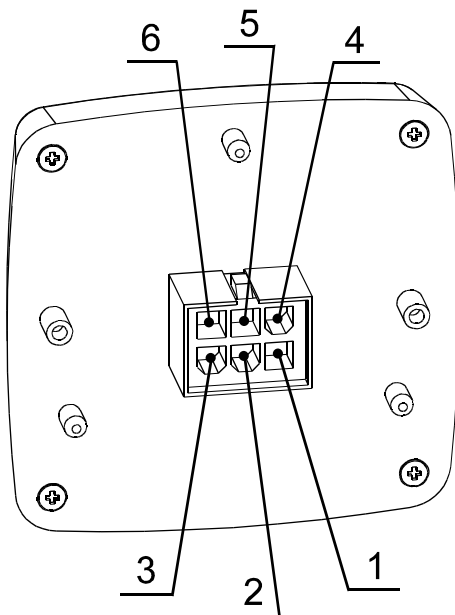

CONNETTORE POSTERIORE A 6 POLI	
PIN	SEGNALE
1	+ batteria
2	Comando DOWN
3	Comando UP
4	Sensore magnetico
5	
6	- batteria

Foratura pannello plancia

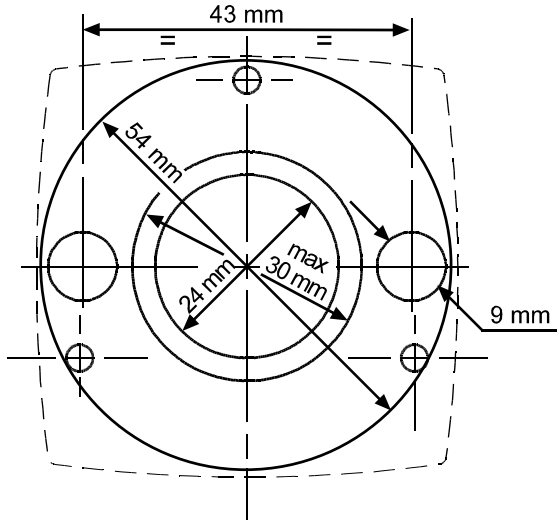

Foratura sensore

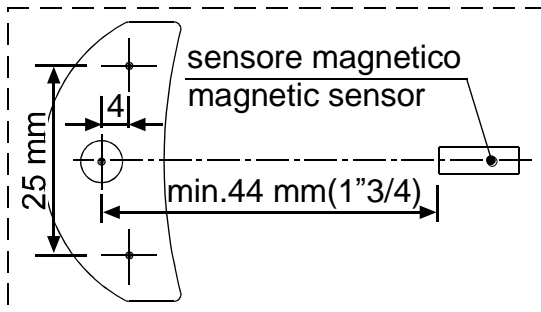

Impostazione contametri



Nota

LO STRUMENTO VIENE FORNITO GIÀ IMPOSTATO IN METRI PER UNA CIRCONFERENZA DEL BARBOTIN PARI A 33 cm.

Per modificare l'impostazione di fabbrica identificare, utilizzando la tabella allegata, il tipo di barbotin e la relativa misura della circonferenza.

Tabella 1

Misura catena	Numero di rientranze	Circonferenza Barbotin (cm)	Circonferenza Barbotin (pollici)
6 mm	6	22	9
	9	34	13
7 mm	6	25	10
8 mm	5	24	9
	6	28	11
	7	33*	13
	8	38	15
10 mm	5	31	12
	6	36	14
12 mm	5	36	14
	6	43	17
13 mm	6	46	18
14 mm	5	42	16

* impostazione dello strumento all'uscita dalla fabbrica

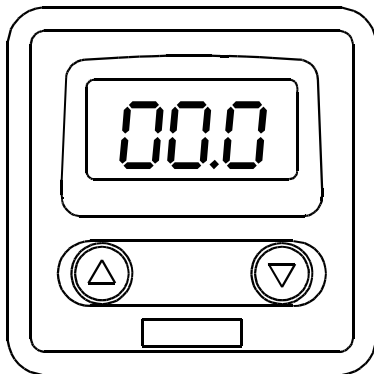

Prima accensione

Il contametri è dotato di un *display* a 3 cifre e di due tasti:





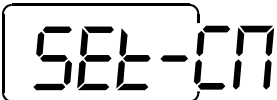





Lo spegnimento dell'illuminazione del *display* avviene 3 minuti dopo l'ultimo comando dato.

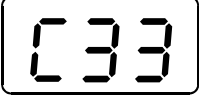

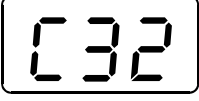

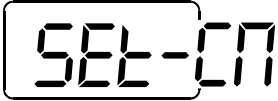
Alla prima accensione lo strumento si predisporrà come da impostazione all'uscita dalla fabbrica.

<p>Sul <i>display</i> scorre la scritta SET CM.</p>	
<p>Lo strumento si predispose per il conteggio in metri, della catena, con incrementi di 0,5 m fino a 99,5 metri e di 1 metro fino a 999 metri.</p>	

Predisposizione al conteggio in metri

1	<p>Premere il tasto  per tre secondi.</p>	
2	<p>Appare successivamente il valore della circonferenza del barbotin programmata in fabbrica (33 cm).</p>	
3	<p>Premere il tasto  per incrementare la numerazione del <i>display</i> fino al raggiungimento del valore dello sviluppo della catena sul barbotin.</p> <p>Premendo il tasto  si diminuisce il valore impostato di una unità (ad esempio 32 cm).</p>	
4	<p>Appare successivamente il fattore di divisione.</p> <p>Se viene utilizzato il sensore induttivo a 3 fili impostare qui il numero di impronte del barbotin ricavato dalla Tabella 1.</p> <p>Se viene utilizzato il sensore magnetico a 2 fili lasciare il valore impostato a 1.</p>	
5	<p>Raggiunto il valore impostato attendere 5 secondi. Sul <i>display</i> scorre la scritta SET CM.</p>	
6	<p>A questo punto lo strumento si predispose per il conteggio in metri, della catena, con incrementi di 0,5 m fino a 99,5 metri e di 1 metro fino a 999 metri.</p>	

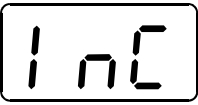
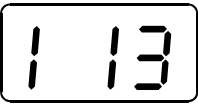
Predisposizione al conteggio in piedi

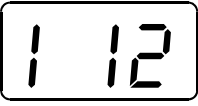
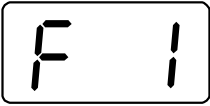
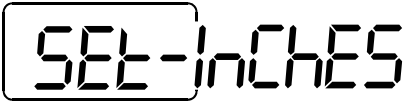
1	<p>Premere il tasto  per tre secondi.</p>	
2	<p>Premere il tasto .</p>	
3	<p>Appare successivamente il valore della circonferenza del barbotin programmata in fabbrica (13").</p>	
4	<p>Premere il tasto  per incrementare la numerazione del <i>display</i> fino al raggiungimento del valore dello sviluppo della catena sul barbotin.</p> <p>Premendo il tasto  si diminuisce il valore impostato di una unità (ad esempio 12").</p>	
5	<p>Appare successivamente il fattore di divisione.</p> <p>Se viene utilizzato il sensore induttivo a 3 fili impostare qui il numero di impronte del barbotin ricavato dalla Tabella 1.</p> <p>Se viene utilizzato il sensore magnetico a 2 fili lasciare il valore impostato a 1.</p>	
6	<p>Raggiunto il valore impostato attendere 5 secondi. Sul <i>display</i> scorre la scritta SET INCHES.</p>	

7	<p>A questo punto lo strumento si predispose per il conteggio in piedi, della catena, con incrementi di 1, 2 o 3 piedi in funzione della misura del barbotin.</p>	
---	---	---



Nota

IN CASO DI INTERRUZIONE DELLE OPERAZIONI DI IMPOSTAZIONE PER PIÙ DI 60 SECONDI LO STRUMENTO RICARICA, AUTOMATICAMENTE, I DATI PRECEDENTEMENTE IMPOSTATI.

Per azzerare la misura tenere premuto il tasto DOWN

per 3 secondi

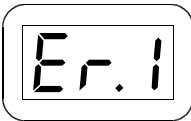
Anomalie di funzionamento

SEGNALAZIONE	CAUSA	RIMEDIO
	<p>Mentre si manteneva premuto il tasto UP o DOWN lo strumento non ha ricevuto nessun segnale dal sensore magnetico per più di 12 secondi.</p>	<p>Verificare i collegamenti elettrici del sensore.</p> <p>Verificare il funzionamento del sensore e se guasto provvedere alla sostituzione.</p> <p>Verificare la posizione del sensore, del magnete sul barbotin e la distanza tra i due (3 mm).</p> <p>Verificare il funzionamento dell'impianto elettrico o del salpa ancora stesso</p>

Garanzia

I nostri articoli sono garantiti contro eventuali difetti di fabbricazione per 2 anni a partire dalla data di acquisto (farà fede lo scontrino fiscale o altra prova d'acquisto). Non sono comprese nella garanzia: avarie e rotture causate dal trasporto, interventi effettuati per problemi causati da erronea installazione, avarie causate da uso improprio dell'apparecchio. La garanzia decade nell'ipotesi di manutenzione o riparazioni effettuate da persone non autorizzate dall'azienda o eseguite con l'applicazione di pezzi di ricambio non originali. La garanzia non prevede in nessun caso l'integrale sostituzione dell'apparecchio. La garanzia si riferisce esclusivamente alla sostituzione dei pezzi difettosi ed alla relativa manodopera. Non comprende il trasporto o le spese di trasferta. Il Cliente non potrà pretendere alcun rimborso per le spese sostenute.

Description

The EV-011 chain counter displays the length of chain let out by an anchor windlass, expressed in metres or feet.



The device does not control the windlass: Up and Down buttons can only set the chaincounter.

Technical data

Power supply	from 10 to 30 V DC
Current intake	max 20 mA
Protection rating of front cover	IP65*
Operating temperature	0 / +70 °C (32 / 158 °F)
Display character height	9 mm
Max. chain length	999 metres – 999 feet
Size (mm)	60 x 60 x 18
Weight (g)	55

* excluding cable connection zone



Warning

CONNECT ONLY TO A DC POWER SUPPLY.

General notes

The EV-011 chain counter must be used solely for the purposes described herein, i.e. to display the number of metres/feet of chain let out by an anchor windlass. Any other use is to be considered improper.

Any tampering with the instrument will result in immediate voiding of the warranty.

Components

The package contains:

- chain counter, seal, closure cover and 2 clamping screws;
- 6-pole male connector with crimp-type 6 male contacts;
- instructions for use.

Installation

Installing the magnet on the anchor windlass

- A hole having a diameter of 6.5 mm (~1/4") and depth of 8 mm (5/16") must be drilled on a tooth of the gipsy, in a place outside the chain's path.
- In the case of vertical shaft anchor windlasses (see Fig. 1B), drill the hole in the lower circumference of the gipsy.
- In the case of horizontal shaft anchor windlasses (see Fig. 2B), drill the hole in the outer circumference of the gipsy.
- Also make sure that the protruding part of the magnet will not collide with the base or sensor during rotation of the gipsy.
- Insert the metal part of the magnet in the hole, allowing the protected part to protrude by about 2 mm. Fix it in place using an adhesive for metals (two-component epoxy glue) or silicone. The glue used must be able to withstand a marine environment.

Installing the magnetic sensor for vertical shaft anchor windlasses

(see Fig. 1A – 1B)

- Drill a 4 mm (~3/16") hole in the cover through which to thread the sensor cable.
- Fasten Part A of the support with the two screws provided, after having positioned the O-ring in the lower part of the support.
- Fit Part B with the magnetic sensor on support A and adjust its height until it is aligned with the magnet fastened on the gipsy.
- Bring the sensor to a distance of about 3 mm (~1/8") from the magnet and secure it in place by tightening screw G1. Then tighten screw G2.

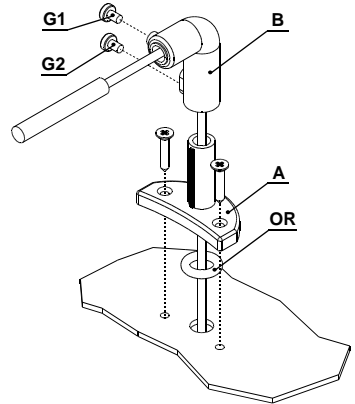

Installing the magnetic sensor for horizontal shaft anchor windlasses

(see Fig. 2A – 2B – 2C)

- Drill a 4 mm (~3/16") hole in the cover through which to thread the sensor cable.
- Fasten Part A of the support with the two screws provided, after having positioned the O-ring in the lower part of the support.
- Cut Part C to measure using a hacksaw. The sensor must be positioned at a distance of about 3 mm (~1/8") from the magnet.
- Fit Part C with the magnetic sensor on support A and fix it in place using an adhesive for plastic (two-component epoxy glue) or silicone.
- Using the same glue, attach the sensor to Part C.

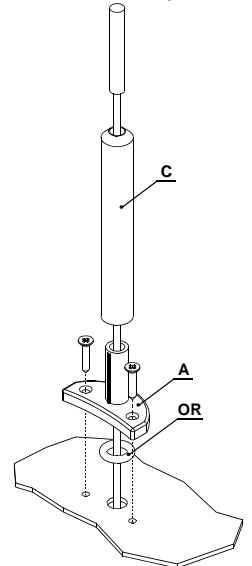

Installing the chain counter

(see connection diagram)



Warning

ALWAYS DISCONNECT THE BATTERY PRIOR TO INSTALLATION.

- The chain counter must be positioned so that the display will be easy to read. It should not be exposed to direct sunlight.
- The rear part of the instrument must be protected from contact with water or moisture.
- The instrument may be fastened to dashboards whose thickness is more than 6 mm (~1/4"). In order to fasten it, please employ M3 x 5 screws for 6 mm (~1/4") dashboards. For bigger thickness please use M3 screws whose length must be 2/3 mm (~1/8") less than the dashboard's thickness.
- In the part to the rear of the dashboard there must be minimum clearance of 35 mm (1" 3/8) and there must also be adequate access to perform installation and maintenance work.
- Make a hole with a diameter of 24 mm (~1") – max. 30 mm (~1" 3/16) – on the dashboard and 2 holes with diameters of 9 mm (~7/16") for the chain counter clamping screws (see figure). Use cutting nippers to cut the three pins on the back of the instrument, position the chain counter and fasten it to the dashboard by tightening the two screws. If the dashboard already has a hole with a 54 mm (2" 1/8) diameter, it is not necessary to cut the pins on the back.

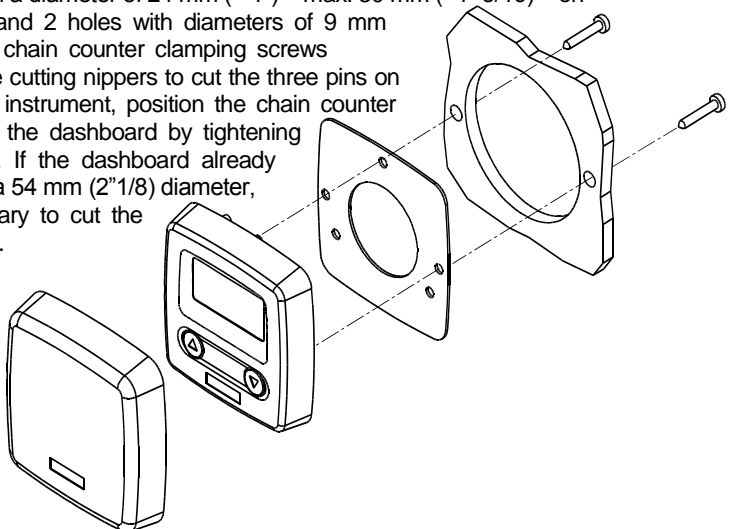

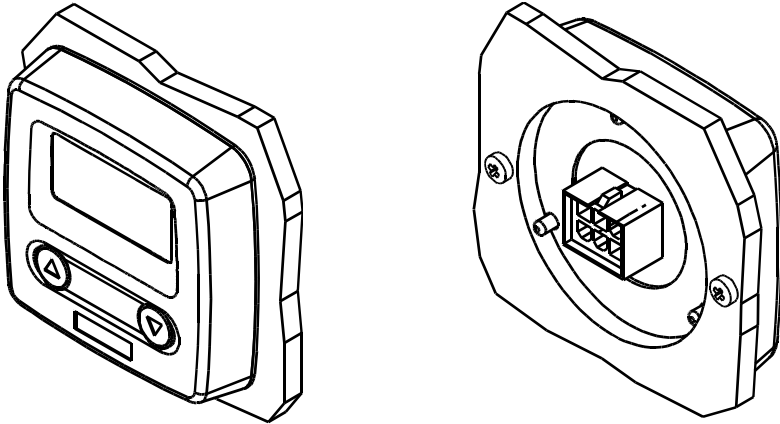

- The seal must be positioned between the cain counter and the dashboard.
- For instructions on making electrical connections, see the attached diagram. The wires must have a minimum cross section size of 1.5 mm². Do not use the voltage generated by the engine battery set to provide power.
- Install a 0.5 A (ampere) safety fuse on the + wire of the battery.
- The instrument complies with EMC standards (EN55022) and must be positioned at a distance of 0.5 metres (1.64 Ft) from radio receiver devices.

Connections

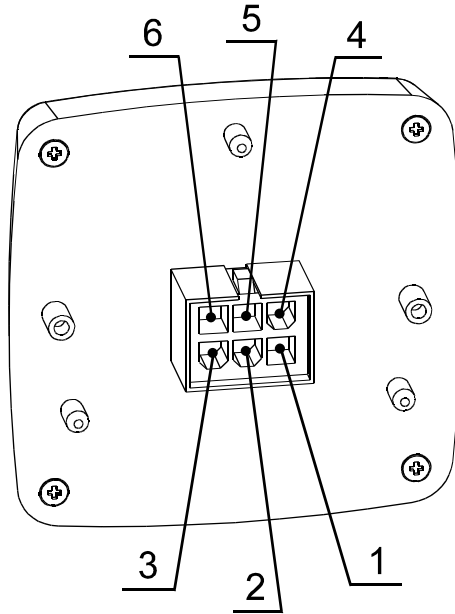

6-POLE REAR CONNECTOR	
PIN	SIGNAL
1	+ battery
2	DOWN command
3	UP command
4	Magnetic sensor
5	
6	- battery

Dashboard hole

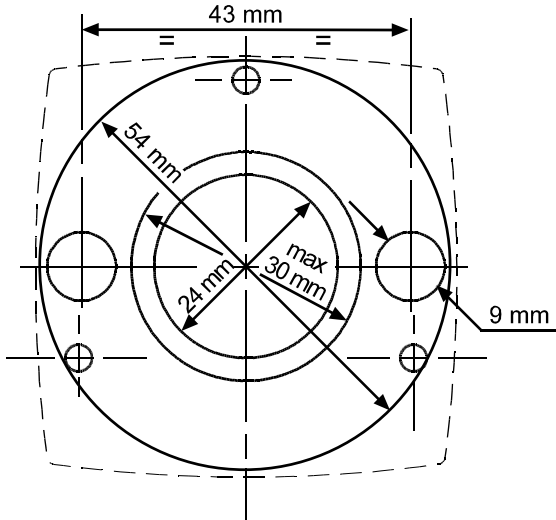

Sensor hole

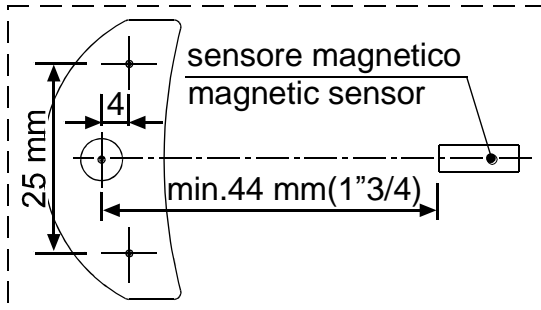

Setting the chain counter



Note

THE INSTRUMENT IS SUPPLIED ALREADY PRE-SET IN METRES FOR A GIPSY CIRCUMFERENCE OF 33 cm.

To change the factory setting, use the table below to identify the type of gipsy and corresponding circumference measurement.

Table 1

Chain Type	Number of recesses	Gipsy Circumference (cm)	Gipsy Circumference (inches)
6 mm	6	22	9
	9	34	13
7 mm	6	25	10
	5	24	9
8 mm	6	28	11
	7	33*	13
	8	38	15
10 mm	5	31	12
	6	36	14
12 mm	5	36	14
	6	43	17
13 mm	6	46	18
14 mm	5	42	16

* factory settings of instrument

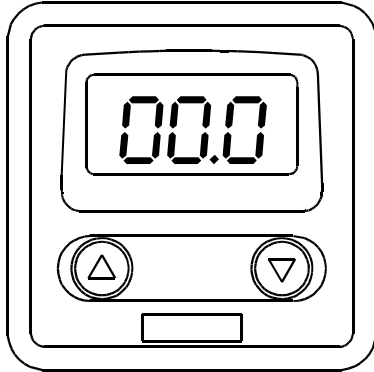

Starting up

The chain counter features a 3-digit display and two buttons:  and .





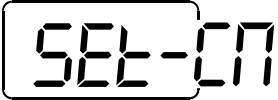





The display backlight will switch off 3 minutes after the last command given.



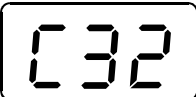

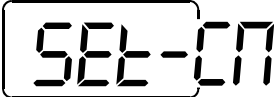





When the instrument is turned on for the first time, it will set up as programmed in the factory.

<p>The words SET CM will run across the display screen.</p>	
<p>The instrument will set up to count chain deployment in metres – in 0.5 m increments up to 99.5 metres and in 1 m increments up to 999 metres.</p>	

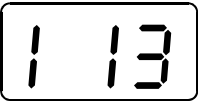
Setting up to count in metres

1	<p>Press  for three second.</p>	
2	<p>Then the gipsy circumference programmed in the factory (33 cm) will be displayed.</p>	
3	<p>Press  to increase the number on the display until reaching the value corresponding to the length of chain on the gipsy.</p> <p>Press  to decrease the set value by one unit (e.g. 32 cm).</p>	
4	<p>Then the division factor will be displayed.</p> <p>If you use the 3-wire inductive sensor set here the number of signatures of the gipsy obtained from Table 1.</p> <p>If you use the 2-wire magnetic sensor leave the value set to 1.</p>	
5	<p>On reaching the set value wait for 5 seconds. The words SET CM will run across the display screen.</p>	
6	<p>At this point the instrument will set up to count chain deployment in metres – in 0.5 m increments up to 99.5 metres and 1 m increments up to 999 metres.</p>	

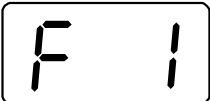
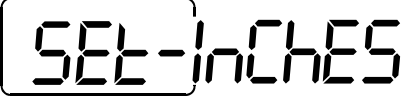
Setting up to count in feet

1	<p>Press  for three second.</p>	
2	<p>Press .</p>	
3	<p>Then the gipsy circumference programmed in the factory (13") will be displayed.</p>	
4	<p>Press  to increase the number on the display until reaching the value corresponding to the length of chain on the gipsy.</p> <p>Press  to decrease the set value by one unit (e.g. 12").</p>	
5	<p>Then the division factor will be displayed.</p> <p>If you use the 3-wire inductive sensor set here the number of signatures of the gipsy obtained from Table 1.</p> <p>If you use the 2-wire magnetic sensor leave the value set to 1.</p>	
6	<p>On reaching the set value wait for 5 seconds. The words SET INCHES will run across the display screen.</p>	
7	<p>At this point the instrument will set up to count chain deployment in feet – in 1, 2 or 3 foot increments depending on the size of the gipsy.</p>	

 **Note**

IF PROGRAMMING OPERATIONS ARE SUSPENDED FOR MORE THAN 60 SECONDS THE INSTRUMENT WILL AUTOMATICALLY RELOAD THE PREVIOUSLY SET DATA.

In order to reset the measure press the DOWN  button for 3 seconds

Troubleshooting

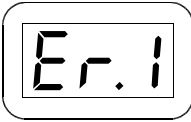
FAULT	CAUSE	CORRECTIVE ACTION
	<p>Though UP or DOWN buttons are pressed, the instrument doesn't receive any signal from the magnetic sensor for more than 12 seconds.</p>	<p>Check the sensor electric connections.</p> <p>Check if sensor operates properly. If not, replace it.</p> <p>Check the position of sensor and magnet on gipsy and their distance (3 mm).</p> <p>Check the operation of electric installation or anchor windlass.</p>

Warranty

We guarantee our products from manufacturing defects for 2 years from the purchase date (purchase ticket or any other purchase proof will be requested). Guarantee does not include damages and breakage during the transport, damages and breakage due to faulty installation or improper use. Warranty is no longer valid when repairs or servicing have been made by unauthorized people or made with spare parts which are not original. Warranty does not include the complete replacement of the goods and refers exclusively to the replace of faulty pieces and necessary labour. It does not include transfer or transport expenses. The Customer will not ask for expenses refund.

Description

Le compteur métrique EV-011 permet l'affichage des mètres ou pieds de chaîne déroulés d'un guindeau.



Le compteur de chaîne ne contrôle pas le guindeau : les touches UP et DOWN ne servent qu'à l'établissement du compteur de chaîne.

Caractéristiques techniques

Tension d'alimentation	de 10 à 30 V DC
Absorption de courant	max 20 mA
Degré de protection habillage partie frontale	IP65*
Température de fonctionnement	0°C à +70°C (32°F à 158 °F)
Hauteur caractères moniteur	9 mm
Longueur maximum mesurable	999 mètres – 999 pieds
Dimensions (mm)	60 x 60 x 18
Poids (g)	55

* zone de connexion des câbles exclue



Attention

ALIMENTER UNIQUEMENT EN COURANT CONTINU.

Notes générales

Le compteur métrique EV-011 doit être utilisé pour la fonction décrite dans le présent manuel, à savoir pour la visualisation des mètres/pieds de chaîne déroulés d'un guindeau. Toute autre utilisation doit être considérée comme impropre.

Toute modification ou opération induite sur l'instrument entraîne l'annulation immédiate de la garantie.

Composants

L'emballage contient:

- compteur métrique, joint, couvercle de fermeture et 2 vis de fixation;
- connecteur mâle 6 pôles, avec 6 contacts mâle à sertir;
- instructions d'utilisation.

Installation

Installation de l'aimant sur le guideau

- Le trou à réaliser sur une dent du barbotin - d'un diamètre de 6,5 mm (~1/4") et d'une profondeur de 8 mm (5/16") - ne doit pas se trouver à hauteur d'une zone de passage de la chaîne.
- Pour les guideaux à axe vertical (voir Fig. 1B), réaliser le trou sur la circonférence inférieure du barbotin.
- Pour les guideaux à axe horizontal (voir Fig. 2B), réaliser le trou sur la circonférence externe du barbotin.
- S'assurer que la partie saillante de l'aimant ne heurte pas la base ni le capteur durant la rotation du barbotin.
- Introduire l'aimant dans le trou par la partie métallique en laissant dépasser d'environ 2 mm la partie protégée. Le fixer à l'aide d'une colle pour métaux (colle époxy bi-composant) ou à l'aide de silicone. La colle utilisée doit résister à l'environnement marin.

Montage du capteur magnétique pour guindeau à axe vertical

(voir Fig. 1A – 1B)

- Réaliser sur le pont un trou de 4 mm de diamètre (~3/16") pour le passage du câble du capteur.
- Fixer l'élément A du support à l'aide des deux vis fournies à cet effet, après avoir positionné sur la partie inférieure de ce dernier le joint torique.
- Placer l'élément B, avec le capteur magnétique, sur le support A et en régler la hauteur de telle sorte qu'il soit aligné sur l'aimant fixé au barbotin.
- Placer le capteur à environ 3 mm (~1/8") de l'aimant et le fixer en serrant la vis G1. Serrer ensuite la vis G2.

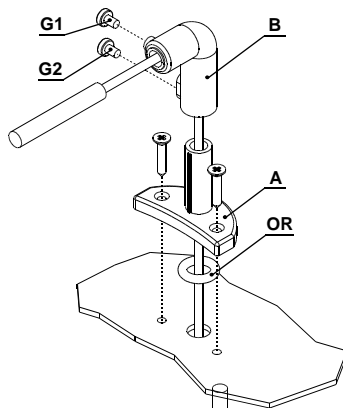

Montage du capteur magnétique pour guindeau à axe horizontal

(voir Fig. 2A – 2B – 2C)

- Réaliser sur le pont un trou de 4 mm de diamètre (~3/16") pour le passage du câble du capteur.
- Fixer l'élément A du support à l'aide des deux vis fournies à cet effet, après avoir positionné sur la partie inférieure de ce dernier le joint torique.
- A l'aide d'une scie, couper l'élément C à la longueur nécessaire. Le capteur doit se trouver à environ 3 mm (~1/8") de l'aimant.
- Placer l'élément C, avec le capteur magnétique, sur le support A et le fixer à l'aide d'une colle pour matériaux plastiques (colle époxy bi-composant) ou à l'aide de silicone.
- A l'aide de la même colle ou de silicone, fixer le capteur à l'élément C.

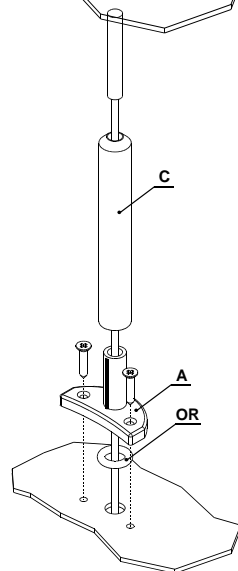

Installation du compteur métrique

(voir schéma électrique)



Attention

VEILLER À DÉBRANCHER LA BATTERIE AVANT DE PROCÉDER À L'INSTALLATION.

- Le compteur métrique doit être positionné de telle sorte que les indications affichées par le moniteur soient facilement lisibles évitant l'exposition aux rayons solaires.
- La partie postérieure du compteur métrique doit être à l'abri de l'eau et de l'humidité.
- L'instrument peut être fixé sur des tableaux de bord dont l'épaisseur est supérieure à 6 mm (~1/4"). Pour fixer l'instrument utiliser vis M3 x 5 pour tableaux de 6 mm (~1/4"). Pour épaisseurs plus grandes, employer des vis M3 de 2/3 mm (~1/8") de longueur moins que l'épaisseur du tableau.
- A l'arrière du tableau de bord, doit être disponible un espace d'au moins 35 mm (~1" 3/8). Un accès doit être en outre prévu pour l'installation et la maintenance.
- Réaliser un trou de 24 mm de diamètre (~ 1") – max. 30 mm – et 2 trous de 9 mm (~7/16") pour les vis de fixation du compteur métrique (voir figure). À l'aide d'une pince coupante éliminer les trois bornes sur la partie arrière de l'instrument, placer le compteur métrique et le fixer sur le tableau de bord et serrer les deux vis. Lorsque sur le tableau de bord est déjà prévu un trou de 54 mm (2" 1/8) les bornes arrière ne doivent pas être coupées.

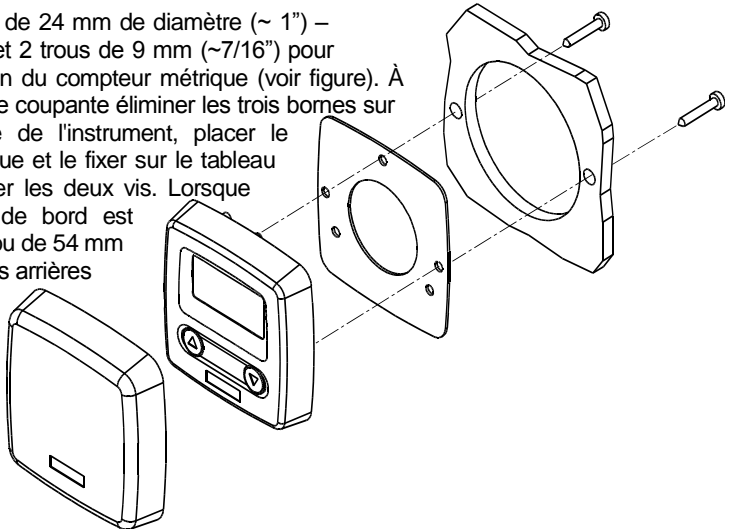

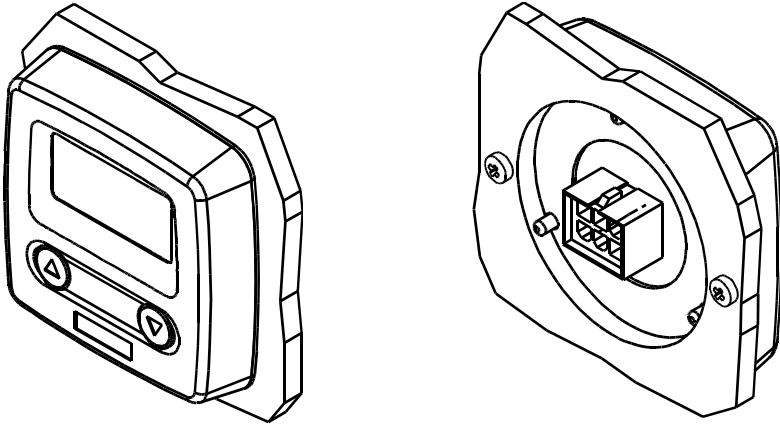

- Le joint doit être placé entre la partie antérieure du panneau du tableau de bord et l'instrument.
- Pour le branchement électrique, se reporter aux indications figurant sur le schéma joint en annexe. Les câbles doivent avoir une section d'au moins 1,5 mm².
- Monter un fusible de protection de 0,5 A (ampère) sur le câble "+" de la batterie. Pour l'alimentation, ne pas utiliser le courant provenant du groupe de batteries moteurs.
- L'instrument répond aux standards EMC (EN55022) et doit se trouver à une distance d'au moins 0,5 mètre (1,64 Ft) d'appareillages radio de réception.

Branchements

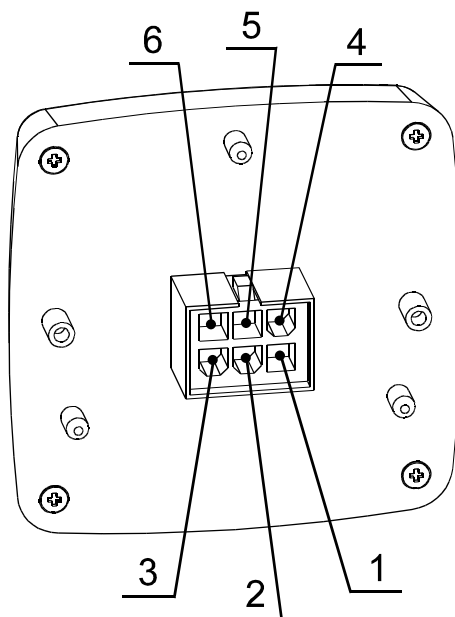

CONNECTEUR POSTÉRIEUR 6 PÔLES	
PIN	SIGNAL
1	+ batterie
2	Commande DOWN
3	Commande UP
4	Capteur magnétique
5	
6	- batterie

Perçage tableau de bord

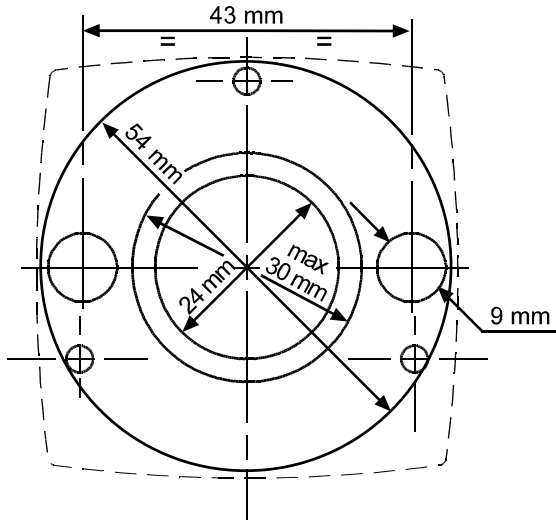

Perçage capteur

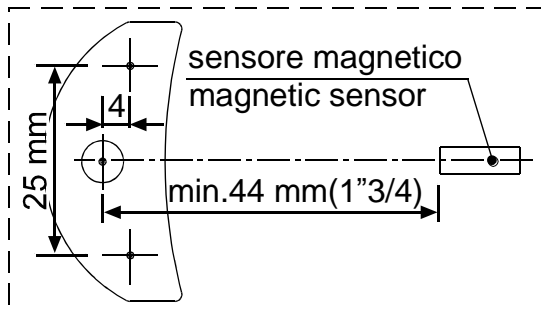

Programmation du compteur métrique



Note

TEL QU'IL EST FOURNI, L'INSTRUMENT EST PROGRAMMÉ POUR LA MESURE EN MÈTRES ET POUR UN BARBOTIN D'UNE CIRCONFÉRENCE DE 33 cm.

Pour modifier la programmation par défaut, identifier, à l'aide du tableau ci-dessous, le type de barbotin et la circonférence correspondante.

Tableau 1

Mesure chaîne	Nombre de renforcements	Circonférence du Barbotin (cm)	Circonférence du Barbotin (pouces)
6 mm	6	22	9
	9	34	13
7 mm	6	25	10
8 mm	5	24	9
	6	28	11
	7	33*	13
	8	38	15
10 mm	5	31	12
	6	36	14
12 mm	5	36	14
	6	43	17
13 mm	6	46	18
14 mm	5	42	16

* programmation par défaut de l'instrument

Premier allumage

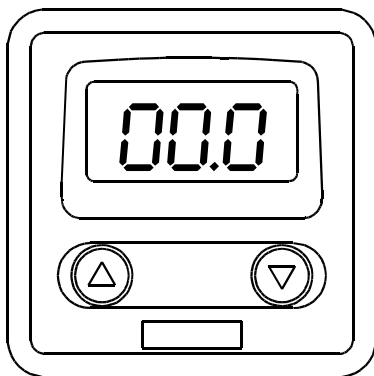

Le compteur métrique est équipé d'un moniteur à 3 chiffres et de deux

touches:  et  .





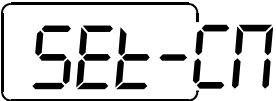





L'extinction de l'éclairage du moniteur se produit 3 minutes après la dernière commande utilisée.

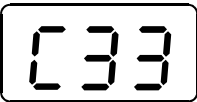

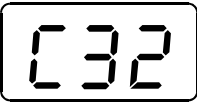

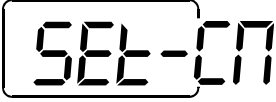



Lors du premier allumage, l'instrument se positionne conformément à la programmation par défaut.

<p>Sur le moniteur défile l'indication SET CM.</p>	
<p>L'instrument est préprogrammé pour le calcul des longueurs de chaîne en mètres, par incrément de 0,5 m jusqu'à 99,5 m et de 1 m jusqu'à 999 m.</p>	

Programmation pour le décompte en mètres

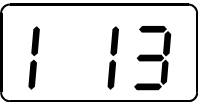
1	<p>Maintenir enfoncée la touche</p>  <p>pendant trois secondes.</p>	
2	<p>S'affiche ensuite la circonférence du barbotin programmée par défaut (33 cm).</p>	
3	<p>Appuyer sur la touche  pour augmenter la valeur affichée sur le moniteur jusqu'à ce que soit atteinte la valeur de la longueur de chaîne sur le barbotin.</p> <p>En appuyant sur la touche , la valeur programmée diminue d'une unité (par exemple 32 cm).</p>	
4	<p>Facteur de division</p> <p>Si vous utilisez le capteur inductif 3 fils mis ici le nombre de signatures obtenues à partir du tableau 1 tzigane.</p> <p>Si vous utilisez le capteur magnétique 2 fils laissez la valeur à 1.</p>	
5	<p>Une fois atteinte la valeur voulue, attendre 5 secondes. Sur le moniteur défile l'indication SET CM.</p>	
6	<p>Une fois ces opérations effectuées, l'instrument est configuré pour le calcul des longueurs de chaîne en mètres, par incrément de 0,5 m jusqu'à 99,5 m et de 1 m jusqu'à 999 m.</p>	

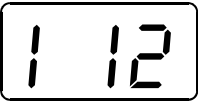
Programmation pour le décompte en pieds

1	Maintenir enfoncée la touche  pendant trois secondes.	
2	Enfoncée la touche  .	
3	S'affiche ensuite la circonférence du barbotin programmée par défaut (13").	
4	Appuyer sur la touche  pour augmenter la valeur affichée sur le moniteur jusqu'à ce que soit atteinte la valeur de la longueur de chaîne sur le barbotin. En appuyant sur la touche  , la valeur programmée diminue d'une unité (par exemple 12").	
5	Facteur de division Si vous utilisez le capteur inductif 3 fils mis ici le nombre de signatures obtenues à partir du tableau 1 tzigane. Si vous utilisez le capteur magnétique 2 fils laissez la valeur à 1.	
6	Une fois atteinte la valeur voulue, attendre 5 secondes. Sur le moniteur défile l'indication SET INCHES.	

7	<p>Une fois ces opérations effectuées, l'instrument est configuré pour le calcul des longueurs de chaîne en pieds, par incrément de 1, 2 ou 3 pieds en fonction des dimensions du barbotin.</p>	
----------	---	---



Note

EN CAS D'INTERRUPTION DES OPÉRATIONS DE PROGRAMMATION PENDANT PLUS DE 60 SECONDES, L'INSTRUMENT RECHARGE AUTOMATIQUEMENT LES DONNÉES PRÉCÉDEMMENT PROGRAMMÉES.

Pour mettre à zéro la donnée, appuyer sur la touche DOWN pendant 3 secondes 

Anomalies de fonctionnement

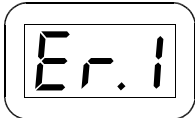
SYMPTÔME	CAUSE	INTERVENTION
	<p>Alors que la touche UP ou DOWN est enfoncée, l'instrument ne reçoit aucun signal du capteur magnétique pendant plus de 12 secondes.</p>	<p>Vérifier les branchements électriques du capteur</p> <p>Vérifier le fonctionnement du capteur. S'il est abîmé, le remplacer.</p> <p>Vérifier la position du capteur et de l'aimant sur le barbotin et la distance entre les deux (3 mm).</p> <p>Vérifier le fonctionnement de l'installation électrique ou du guindeau.</p>

Garantie

Nos produits sont certifiés contre les éventuels défauts de fabrication pendant deux ans à partir de la date d'achat (le ticket de caisse ou autre preuve d'achat feront foi). La garantie ne comprend pas: pannes et ruptures causées par le transport, interventions effectuées dues à mauvaise installation, pannes causées par emploi erroné de l'appareil. La garantie n'est pas valide en cas d'entretien ou réparation effectuées par des personnes qui ne sont pas autorisées, ou bien avec des rechanges qui ne sont pas originaux. La garantie ne prévoit pas en aucun cas le remplacement total de l'appareil; elle ne concerne que les pièces défectueuses et la manoeuvre. Elle ne comprend non plus les frais de transport et les éventuels frais de déplacement. Le Client ne pourra demander aucun remboursement des frais payées.

Beschreibung

Der Meterzähler EV-011 erlaubt die Anzeige der von einem Ankerspill abgewickelten Kettelänge in Metern oder Fuß.



Das Gerät verfügt nicht über die Winde-Kontrollfunktion: Die Auf- und Ab-Tasten werden nur für die Einstellung des Instruments verwendet.

Technische Merkmale

Anschlussspannung	von 10 bis 30 VDC
Stromaufnahme	max 20 mA
Schutzgrad Gehäusevorderseite	IP65*
Betriebstemperatur	0 / +70 °C (32 / 158 °F)
Schriftzeichengrösse <i>Display</i>	9 mm
Max. erreichbares Maß	999 Meter – 999 Fuß
Abmessungen (mm)	60 x 60 x 18
Gewicht (g)	55

* ausgenommen Kabelanschlussbereich



Achtung

AUSSCHLIESSLICH AN GLEICHSTROM ANSCHLIESSEN.

Allgemeine Hinweise

Der Meterzähler EV-011 darf nur für die in diesem Handbuch beschriebenen Zwecke verwendet werden: Anzeige von Metern/Fuß einer von einem Ankerspill abgewickelten Kette. Jeder andere Gebrauch ist unzulässig.

Mutwillige Änderungen am Instrument führen zum sofortigen Verfall der Garantie.

Komponenten

Die Packung enthält:

- Meterzähler, Dichtung, Verschlussdeckel und 2 Befestigungsschrauben;
- 6poliger Stecker mit 6 Steckkontakten zum Crimpen;
- Gebrauchsanweisung.

Installation

Installation des Magneten im Ankerspill

- Das Bohrloch an einem Zahn der Kettennuss - Durchmesser 6,5 mm (~1/4") und Tiefe 8 mm (5/16") – muss an einer Stelle gebohrt werden, an der die Kette nicht durchläuft.
- Für das Ankerspill mit Vertikalachse (siehe Fig. 1B) muss die Bohrung im unteren Kreis der Kettennuss gebohrt werden.
- Für das Ankerspill mit Horizontalachse (siehe Fig. 2B) muss die Bohrung im äußeren Kreis der Kettennuss gebohrt werden.
- Es muss zudem überprüft werden, dass der hervorragende Teil des Magneten während der Drehung der Kettennuss die Unterlage oder den Sensor nicht berührt.
- Den Magneten mit dem Metallteil in das Bohrloch einsetzen und den geschützten Teil ca. 2 mm vorstehen lassen. Mit einem Metallkleber (Zweikomponenten-Epoxydkleber) oder Silikon befestigen. Der Kleber muss salzwasserbeständig sein.

Montage des Magnetsensors für Ankerspill mit Vertikalachse

(siehe Fig. 1A – 1B)

- Ein Loch mit 4 mm ($\sim 3/16''$) Durchmesser als Kabeldurchgang für den Sensor in das Deck bohren.
- Den O-Ring in den unteren Teil des Teils A der Halterung einsetzen und diese mit den zwei mitgelieferten Schrauben festschrauben.
- Das Teil B mit dem Magnetsensor auf die Halterung A montieren und in der Höhe so einstellen, dass dieser sich auf gleicher Achse wie der Magnet auf der Kettennuss befindet.
- Den Sensor bis ca. 3 mm ($\sim 1/8''$) an den Magnet annähern und mit der Schraube G1 festschrauben. Danach die Schraube G2 anziehen.

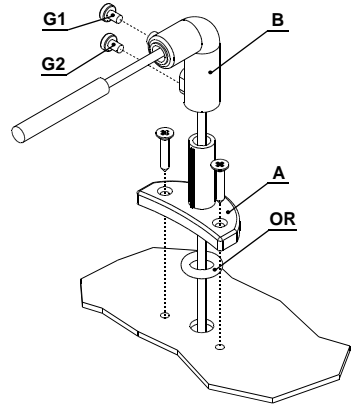

Montage des Magnetsensors für Ankerspill mit Horizontalachse

(siehe Fig. 2A – 2B – 2C)

- Ein Loch mit 4 mm ($\sim 3/16''$) Durchmesser als Kabeldurchgang für den Sensor in das Deck bohren.
- Den O-Ring in den unteren Teil des Teils A der Halterung einsetzen und diese mit den zwei mitgelieferten Schrauben festschrauben.
- Das Teil C mit einer Säge zuschneiden. Der Sensor muss ca. 3 mm ($\sim 1/8''$) vom Magnet entfernt positioniert werden.
- Das Teil C mit dem Magnetsensor auf die Halterung A montieren und mit einem Metallkleber (Zweikomponenten-Epoxydkleber) oder Silikon befestigen.
- Mit dem gleichen Kleber den Sensor an das Teil C befestigen.

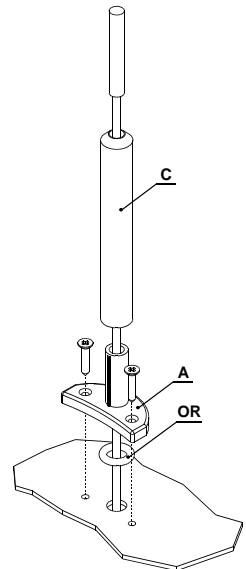

Installation des Meterzählers

(siehe Stromlaufplan)



Achtung

VOR DER INSTALLATION DIE BATTERIE IMMER ABKLEMMEN.

- Der Meterzähler muss so positioniert sein, dass das *Display* gut ablesbar ist und nicht dem Sonnenlicht ausgesetzt ist.
- Die Rückseite des Meterzählers muss vor Wasser und Feuchtigkeit geschützt sein.
- Das Werkzeug kann an Kommandobrücke, die eine Dicke über 6 mm (~1/4") haben, befestigt werden. Um das Wekzeug zu befestigen, benutzen Sie M3 x 5 Schrauben für Kommandobrücke von 6 mm (~1/4"). Wenn die Dicke mehr misst, benutzen Sie M3 Schrauben, die 2/3 mm (~1/8") weniger lang als die Dicke der Kommandobrücke sein.
- Auf der Rückseite des Armaturenbretts muss mindestens 35 mm (1" 3/8) Platz vorhanden sein. Zudem muss ein Zugang für die Installations- und Wartungsarbeiten vorhanden sein.

- Bohren Sie ein Loch in der Kommandobrücke, das eine Weite von 24 mm (~1") – max. 30 mm (~1" 3/16) hat, und zwei andere Löcher von 9 mm (~7/16") für die Schrauben, die den Metermesser befestigen (Schauen Sie das Bild an). Mit einer Schneidezange die drei Sprossen auf der Rückseite des Instruments abschneiden, den Meterzähler anbringen und mit den vier Schrauben am Armaturenbrett festschrauben. Falls im Instrumentenbrett bereits eine Aufnahme von 54 mm (2" 1/8) Durchmesser vorhanden ist, müssen die Sprossen nicht abgeschnitten werden.

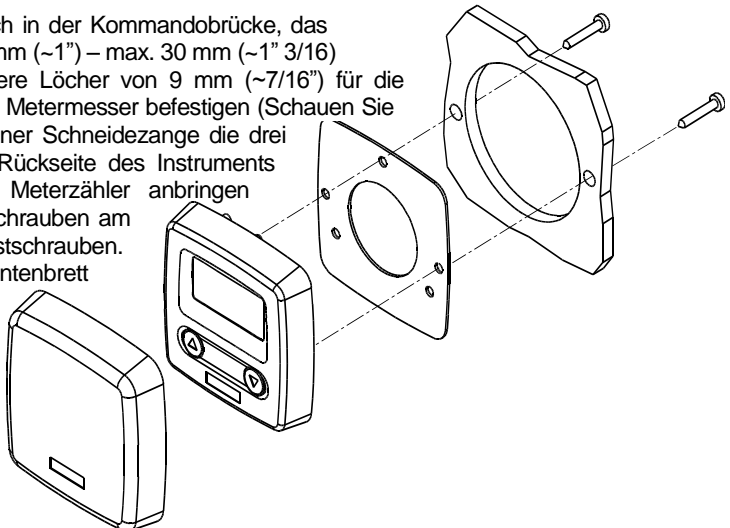

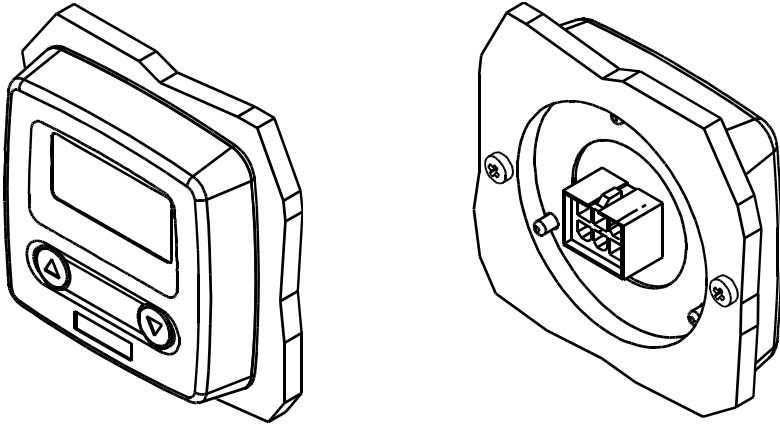

- Die Dichtung muss zwischen die Vorderseite des Armaturenbretts und das Instrument eingelegt werden.
- Für den Stromanschluss sind die Anweisungen des beiliegenden Stromlaufplans zu befolgen. Die Kabel müssen einen Mindestquerschnitt von 1,5 mm² aufweisen.
- Im Kabel + der Batterie eine Sicherung von 0,5 A (Ampere) installieren. Für die Stromzufuhr nicht die Spannung von den Motorbatterien verwenden.
- Das Instrument entspricht den EMC-Standards (EN55022) und muss mindestens 0,5 m (1,64 Fuß) von Funkempfängern platziert werden.

Anschlüsse

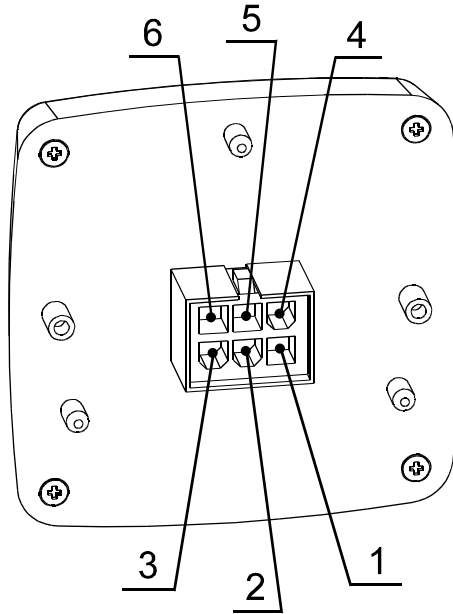

HINTERE 6 POLIGE STECKVERBINDUNG	
PIN	SIGNAL
1	+ batterie
2	Steuerung DOWN
3	Steuerung UP
4	Magnetsensor
5	
6	- batterie

Bohr Kommandobrücke

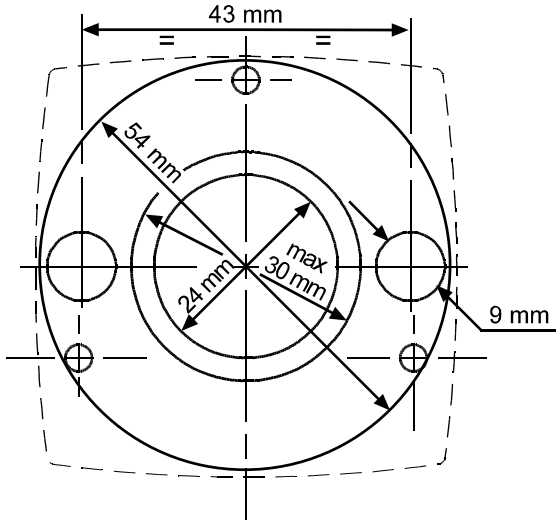

Bohr Sensor

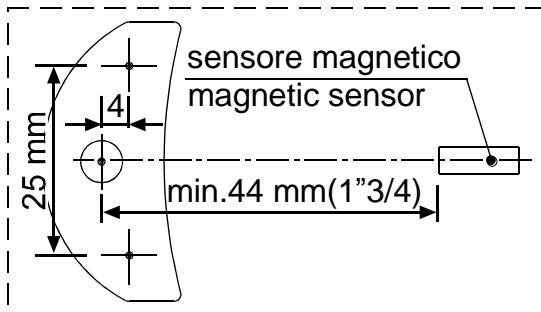

Einstellung des Meterzählers



Anmerkung

DAS GERÄT IST BEI DER AUSLIEFERUNG AUF METER FÜR EINEN KETTENUSSUMFANG VON 33 cm EINGESTELLT.

Zur Änderung der Werkseinstellung anhand der nachstehenden Tabelle den Kettentyp mit dem entsprechenden Umfang herausuchen.

Tabelle 1

Kettentyp	Anzahl Aussparungen	Umfang Kettennuss (cm)	Umfang Kettennuss (Zoll)
6 mm	6	22	9
	9	34	13
7 mm	6	25	10
8 mm	5	24	9
	6	28	11
	7	33*	13
	8	38	15
10 mm	5	31	12
	6	36	14
12 mm	5	36	14
	6	43	17
13 mm	6	46	18
14 mm	5	42	16

* Werkseinstellung des Instruments

Erstes Einschalten

Der Meterzähler ist mit einem 3stelligen *Display* und den zwei Tasten



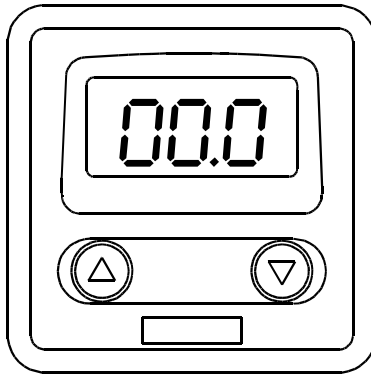

und .





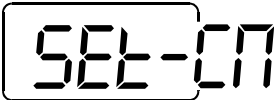







Die Beleuchtung des *Displays* schaltet 3 Minuten nach dem letzten Steuerbefehl aus.





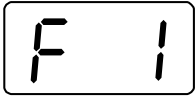
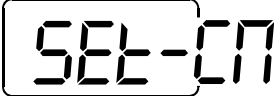



Beim ersten Einschalten zeigt das Gerät die Werkseinstellung an.

<p>Auf dem <i>Display</i> läuft der Text SET CM.</p>	
<p>Das Instrument stellt sich auf das Zählen in Metern der Kette mit Sprüngen von 0,5 Meter bis 99,5 Meter und 1 Meter bis 999 Meter ein.</p>	

Einstellung auf Zählen in Metern

1	 Die Taste  drei Sekunden lang drücken.	
2	Danach  erscheint die Werkseinstellung  des Kettenussumfangs (33 cm).	
3	Die Taste  zur Erhöhung der <i>Display-Nummerierung</i> drücken, bis der Wert der Kettenlänge auf der Kettenuss erreicht ist. Durch Drücken der  wird der Einstellwert um eine Einheit verringert (zum Beispiel 32 cm).	
4	Teilungsfaktor Wenn Sie die induktiven Sensor verwenden 3-Leiter eingestellt hier die Anzahl der Unterschriften von der Zigeunerin Tabelle 1 erhalten. Wenn Sie den magnetischen Sensor verwenden 2 Drähte lassen Sie den Wert auf 1 gesetzt.	
5	Ist der Einstellwert erreicht, 5 Sekunden lang warten. Auf dem <i>Display</i> läuft der Text SET CM.	
6	Das Instrument stellt sich nun auf das Zählen in Metern der Kette mit Sprüngen von 0,5 Meter bis 99,5 Meter und 1 Meter bis 999 Meter ein.	

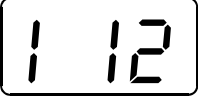
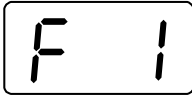
Einstellung auf Zählen in Fuß

1	<p>Die Taste  drei Sekunden lang drücken.</p>	
2	<p>Die Taste  drücken.</p>	
3	<p>Danach erscheint die Werkseinstellung Kettenussumfangs (13").</p>	
4	<p>Die Taste  zur Erhöhung der <i>Display-Nummerierung</i> drücken, bis der Wert der Kettenlänge auf der Kettenuss erreicht ist.</p> <p>Durch Drücken der  wird der Einstellwert um eine Einheit verringert (zum Beispiel 12").</p>	
5	<p>Teilungsfaktor Wenn Sie die induktiven Sensor verwenden 3-Leiter eingestellt hier die Anzahl der Unterschriften von der Zigeunerin Tabelle 1 erhalten. Wenn Sie den magnetischen Sensor verwenden 2 Drähte lassen Sie den Wert auf 1 gesetzt.</p>	
6	<p>Ist der Einstellwert erreicht, 5 Sekunden lang warten. Auf dem <i>Display</i> läuft der Text SET INCHES.</p>	

7	Das Instrument stellt sich nun auf das Zählen in Fuß der Kette mit Sprüngen von 1, 2 oder 3 Fuß je nach Größe der Kettennuss.	
---	---	---



Anmerkung

WERDEN DIE EINSTELLSCHRITTE FÜR MEHR ALS 60 SEKUNDEN UNTERBROCHEN, LÄDT DAS INSTRUMENT AUTOMATISCH WIEDER DIE BEREITS GESPEICHERTEN DATEN.

Um auf Null zu drücken Sie die DOWN-Taste



für 3 Sekunden

Betriebsstörungen

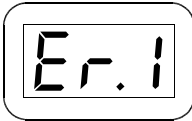
MELDUNG	URSACHE	BEHEBUNG
	Während die Taste UP oder DOWN gedrückt wurde, hat das Instrument mehr als 12 Sekunden lang kein Signal vom Magnetsensor erhalten.	<p>Die Stromanschlüsse des Sensors überprüfen.</p> <p>Die Funktionsweise des Sensors überprüfen und diesen eventuell ersetzen.</p> <p>Die Position des Sensors, des Magnets auf der Kettennuss und den Abstand zwischen den beiden (3 mm) überprüfen.</p> <p>Die Funktionsweise der elektrischen Anlage oder des Ankerspills überprüfen.</p>

Garantie

Unsere Artikel haben eine Garantie gegen Produktionsfehler von 2 Jahre ab dem Kaufdatum (Kassenbon oder anderer Kaufbeleg). In der Garantie sind nicht enthalten: Störungen oder Beschädigungen durch den Transport, Eingriffe wegen falscher Installierung, Störungen durch falscher Anwendung des Apparates. Die Garantie entfällt falls die Reparatur durch von der Firma nicht autorisierte Personen oder mit nicht originalen Ersatzteilen erfolgt. Die Garantie sieht auf keinen Fall den kompletten Ersatz des Apparates. Die Garantie haftet nur für mangelhafte Teile und der relativen Arbeitszeit. Sie deckt nicht den Transport oder die Aufwandsentschädigung. Der Kunde kann keine Erstattung der Unkosten verlangen.

Descripción

El cuentametros EV-011 permite visualizar los metros o pies de cadena desenrollados desde un molinete.



El instrumento no tiene la función de control del molinete: los botones arriba y abajo sólo se utilizan para fijar el instrumento.

Datos técnicos

Tensión de alimentación	entre 10 y 30 V DC
Consumo de corriente	máx. 20 mA
Grado de protección envoltorio parte frontal	IP65*
Temperatura operativa	0 / +70 °C (32 / 158 °F)
Altura caracteres pantalla	9 mm
Medición máxima posible	999 metros / 999 pies
Tamaño (mm)	60 x 60 x 18
Peso (g)	55

* excluida la zona de conexión de los cables



Atención

ALIMENTAR EXCLUSIVAMENTE CON CORRIENTE CONTINUA.

Notas de carácter general

El cuentametros EV-011 debe ser utilizado para los fines descritos en este manual: visualización de los metros/pies de cadena desenrollados desde un molinete. Cualquier otro uso se considerará como impropio.

La alteración del instrumento provocará la invalidación inmediata de la garantía.

Componentes

Componentes:

- cuentametros, guarnición, tapa de cierre y 2 tornillos de fijación;
- conector macho de 6 polos con 6 contactos macho a engarzar;
- instrucciones de uso.

Instalación

Instalación del imán en el molinete

- Se debe practicar un agujero en un resalte del barbotén de diámetro 6,5 mm (~1/4") y profundidad 8 mm (5/16"). Practicar este agujero en una zona no coincidente con el paso de la cadena.
- En el caso de molinetes de eje vertical (véase Fig. 1B), practicar el agujero en la circunferencia inferior del barbotén.
- En el caso de molinetes de eje horizontal (véase Fig. 2B), practicar el agujero en la circunferencia externa del barbotén.
- Controlar que durante la rotación del barbotén, la parte saliente del imán no golpee ni la base ni el sensor.
- Introducir el imán en el agujero por la parte metálica dejando que la parte protegida sobresalga en la medida aproximada de 2 mm. Fijar el imán utilizando un pegamento para metales (cola epoxídica bi-componente) o silicona. El pegamento utilizado debe ser resistente al ambiente marino.

Montaje sensor magnético para molinetes de eje vertical (véanse Fig. 1A y 1B)

- Practicar en la cubierta un agujero de diámetro 4 mm (~3/16") para permitir el paso del cable del sensor.
- Fijar el elem. A del soporte, utilizando para ello los dos tornillos adjuntos, una vez posicionada la junta tórica en la parte inferior del mismo.
- Introducir el elem. B, con el sensor magnético, en el soporte A y regular su altura de manera que quede alineado con el imán fijado en el barbotén.
- Acercar el sensor de manera que quede a una distancia aproximada de 3 mm (~1/8") respecto del imán y fijarlo apretando el tornillo G1. A continuación, apretar el tornillo G2.

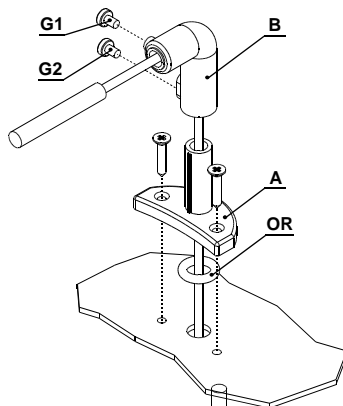

Montaje sensor magnético para molinetes de eje horizontal (véanse Fig. 2A, 2B y 2C)

- Practicar en la cubierta un agujero de diámetro 4 mm (~3/16") para permitir el paso del cable del sensor.
- Fijar el elem. A del soporte, utilizando para ello los dos tornillos adjuntos, una vez posicionada la junta tórica en la parte inferior del mismo.
- Mediante una sierra cortar a la medida el elem. C. El sensor debe quedar posicionado aproximadamente a 3 mm (~1/8") respecto del imán.
- Introducir el elem. C, con el sensor magnético, en el soporte A y fijarlo utilizando un pegamento para materiales plásticos (cola epoxídica bi-componente) o silicona.
- Utilizando el mismo pegamento, fijar el sensor en el elem. C.

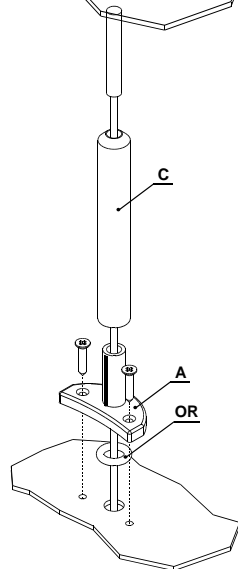

Instalación del cuentametros

(véase esquema eléctrico)



Atención

DESCONECTAR SIEMPRE LA BATERÍA ANTES DE EFECTUAR LA INSTALACIÓN.

- El cuentametros debe quedar posicionado de manera que la pantalla pueda visualizarse fácilmente y sin que quede expuesta a los rayos solares.
- La parte trasera del cuentametros debe estar protegida del contacto con el agua o de la humedad.
- El instrumento puede ser fijado en panel de mandos de espesor mayor de 6 mm (~1/4"). Para fijar utilizar tornillos M3 x 5 para paneles de 6 mm (~1/4"). Para espesor mayor utilizar tornillos M3 con longitud inferior a 2/3 mm (~1/8") al espesor del panel.
- En la parte trasera del puente de mando debe existir un espacio mínimo de 35 mm (~1 3/8"). Además, debe existir un acceso para la instalación y el mantenimiento.
- Practicar en el panel de mando un agujero de diámetro 24 mm (~1") – max. 30 mm – y 2 agujeros de 9 mm (~7/16") para los tornillos de fijación del cuentametros (véase figura). Cortar con una tenaza los tres vástagos situados en la parte trasera del instrumento, posicionar el cuentametros y apretar los dos tornillos para fijarlo al panel. En caso de que en el panel de mando exista ya un agujero de 54 mm (2 1/8") no será necesario cortar los vástagos traseros.

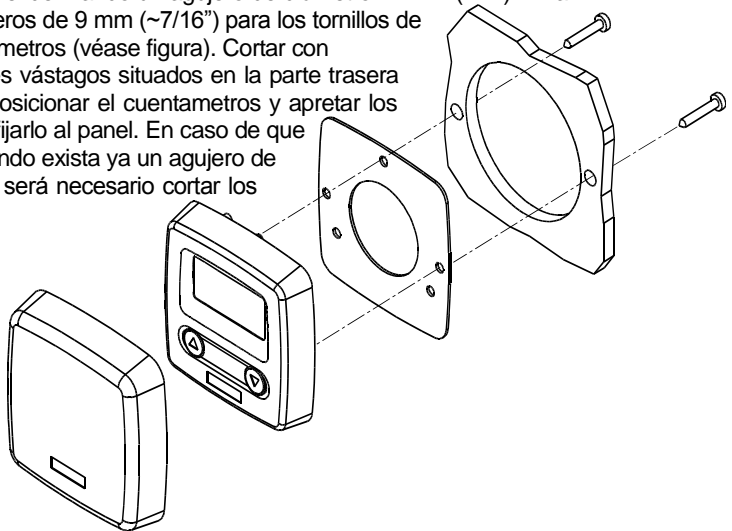

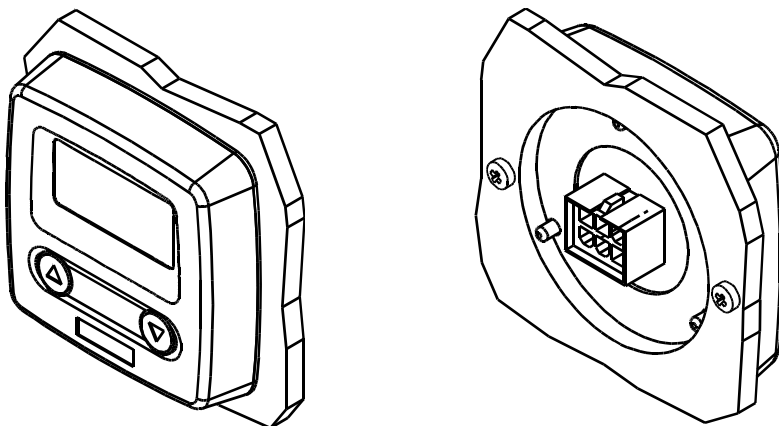

- La guarnición debe ser colocada entre la parte delantera del panel del puente de mando y el instrumento.
- Para efectuar la conexión eléctrica aplicar las instrucciones que aparecen en el esquema anexo. La sección mínima de los cables debe ser de 1,5 mm².
- Instalar un fusible de protección de 0,5 A (amperio) en el cable (+) de la batería. No utilizar para la alimentación la tensión proveniente del conjunto de baterías de los motores.
- El instrumento está conforme con lo establecido por los estándares EMC (EN55022) y debe ser posicionado a una distancia de 0,5 metros (1,64 pies) respecto de equipos radio-receptores.

Conexiones

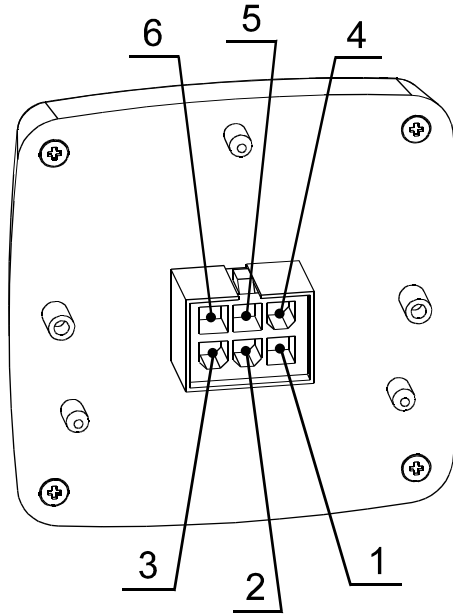

CONECTOR TRASERO DE 6 POLOS	
PIN	SEÑAL
1	+ batería
2	Mando DOWN
3	Mando UP
4	Sensor magnético
5	
6	- batería

Perforación panel de mando

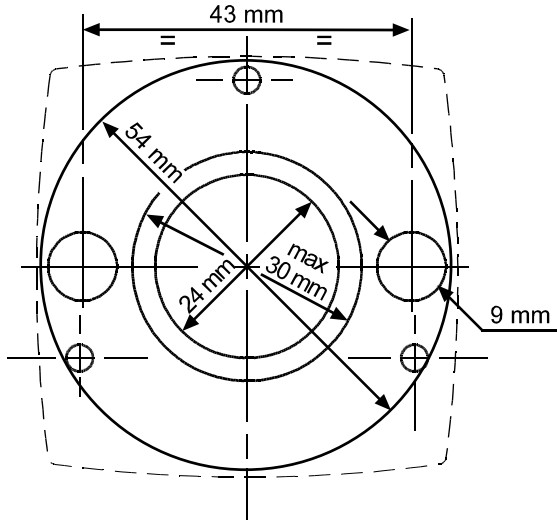

Perforación sensor

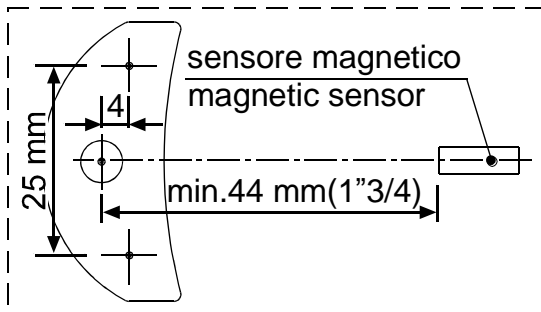

Configuración del cuentametros



Nota

EL INSTRUMENTO ES SUMINISTRADO YA CONFIGURADO EN METROS PARA UNA CIRCUNFERENCIA DEL BARBOTÉN DE 33 cm.

Para modificar la configuración de fábrica, se deberán identificar el tipo de barbotén y la respectiva medida de la circunferencia, utilizando para ello la tabla adjunta.

Tabla 1

Medida cadena	Número de muescas	Circunferencia Barbotén (cm)	Circunferencia Barbotén (pulgadas)
6 mm	6	22	9
	9	34	13
7 mm	6	25	10
8 mm	5	24	9
	6	28	11
	7	33*	13
	8	38	15
10 mm	5	31	12
	6	36	14
12 mm	5	36	14
	6	43	17
13 mm	6	46	18
14 mm	5	42	16

* programación del instrumento efectuada en la fábrica

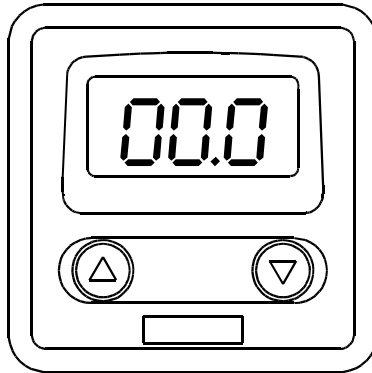

Primer encendido

El cuentametros está provisto de una *pantalla* de 3 cifras y de dos teclas:





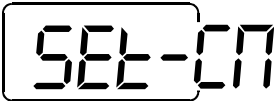





El monitor se apagará 3 minutos después del último mando dispuesto

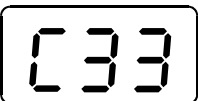

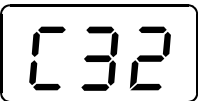

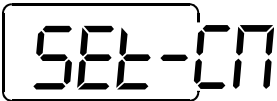



Al ser encendido por primera vez, el instrumento se predispone de la manera configurada en fábrica.

<p>En la <i>pantalla</i> se desplazará el mensaje SET CM.</p>	
<p>El instrumento está configurado para efectuar el conteo en metros de la cadena, con incrementos desde 0,5 hasta 99,5 metros y desde 1 hasta 999 metros.</p>	

Configuración del conteo en metros

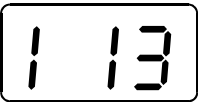
1	<p>Presionar la tecla  durante tres segundos.</p>	
2	<p>A continuación, se visualizará el valor configurado en fábrica (33 cm) de la circunferencia del barbotén.</p>	
3	<p>Presionar la tecla  para incrementar la numeración en la <i>pantalla</i> hasta obtener el valor de desenrollado de la cadena en el barbotén.</p> <p>Presionar la tecla  se reduce el valor programado en la medida de una unidad (por ejemplo, 32 cm).</p>	
4	<p>Factor de división <i>Si se utiliza el sensor inductivo de 3 hilos establecer aquí el número de firmas obtenidas a partir de la Tabla 1 gitana.</i> <i>Si se utiliza el sensor magnético de 2 hilos deje el valor en 1.</i></p>	
5	<p>Una vez obtenido el valor programado esperar 5 segundos. En la <i>pantalla</i> se desplazará el mensaje SET CM.</p>	
6	<p>A continuación, el instrumento queda configurado para el conteo en metros de la cadena, con incrementos desde 0,5 hasta 99,5 metros y desde 1 hasta 999 metros.</p>	

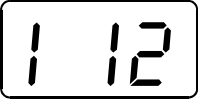
Configuración del conteo en pies

1	<p>Presionar la tecla  durante tres segundos.</p>	
2	<p>Presionar la tecla .</p>	
3	<p>A continuación, se visualizará el valor configurado en fábrica (13") de la circunferencia del barbotén.</p>	
4	<p>Presionar la tecla  para incrementar la numeración en la <i>pantalla</i> hasta obtener el valor de desenrollado de la cadena en el barbotén.</p> <p>Presionar la tecla  se reduce el valor programado en la medida de una unidad (por ejemplo, 12").</p>	
5	<p>Factor de división <i>Si se utiliza el sensor inductivo de 3 hilos establecer aquí el número de firmas obtenidas a partir de la Tabla 1 gitana.</i> <i>Si se utiliza el sensor magnético de 2 hilos deje el valor en 1.</i></p>	
6	<p>Una vez obtenido el valor programado esperar 5 segundos. En la <i>pantalla</i> se desplazará el mensaje SET INCHES.</p>	

7	De esta forma el instrumento queda configurado para el conteo en pies de la cadena, con incrementos de 1, 2 ó 3 pies en función de la medida del barbotén.	
---	--	---

 **Nota**

EN CASO DE INTERRUPCIÓN DE LAS OPERACIONES DE CONFIGURACIÓN DURANTE MÁS DE 60 SEGUNDOS, EL INSTRUMENTO SE RECONFIGURARÁ DE MODO AUTOMÁTICO CON LOS DATOS PRECEDENTEMENTE PROGRAMADOS.

Para cancelar la medida pulse el botón DOWN  durante 3 segundos

Anomalías de funcionamiento

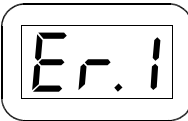
SEÑAL	CAUSA	REMEDIOS
	Mientras se mantiene presionada la tecla UP o DOWN el instrumento no recibe ninguna señal proveniente del sensor magnético durante un lapso superior a 12 segundos.	<p>Controlar las conexiones eléctricas del sensor.</p> <p>Controlar el estado del sensor y sustituirlo en caso de estar averiado.</p> <p>Controlar la posición del sensor, del imán en el barbotén y la distancia entre ambos (3 mm).</p> <p>Controlar el funcionamiento del sistema eléctrico o del molinete.</p>

Garantía

Nuestros artículos están garantizados contra eventuales defectos de fabricación pro 2 años a partir de la fecha de compra (servirá de constancia el recibo fiscal u otra prueba de compra). No están incluidas en la garantía: averías y roturas causadas por el transporte, intervenciones efectuadas por problemas causados por errónea instalación, averías causadas por uso inapropiado del aparato. La garantía caduca en la hipótesis de mantenimiento o reparaciones efectuadas por personas no autorizadas por la empresa o ejecutadas con aplicación de repuestos no originales. La garantía no prevé en ningún caso la completa sustitución del aparato. La garantía se refiere exclusivamente a la sustitución de repuestos defectuosos y correspondiente mano de obra. No comprende el transporte o los gastos de traslado. El Cliente no podrá pretender ningún reembolso por los gastos sostenido.

SCHEMA ELETTRICO / ELECTRICAL DRAWING

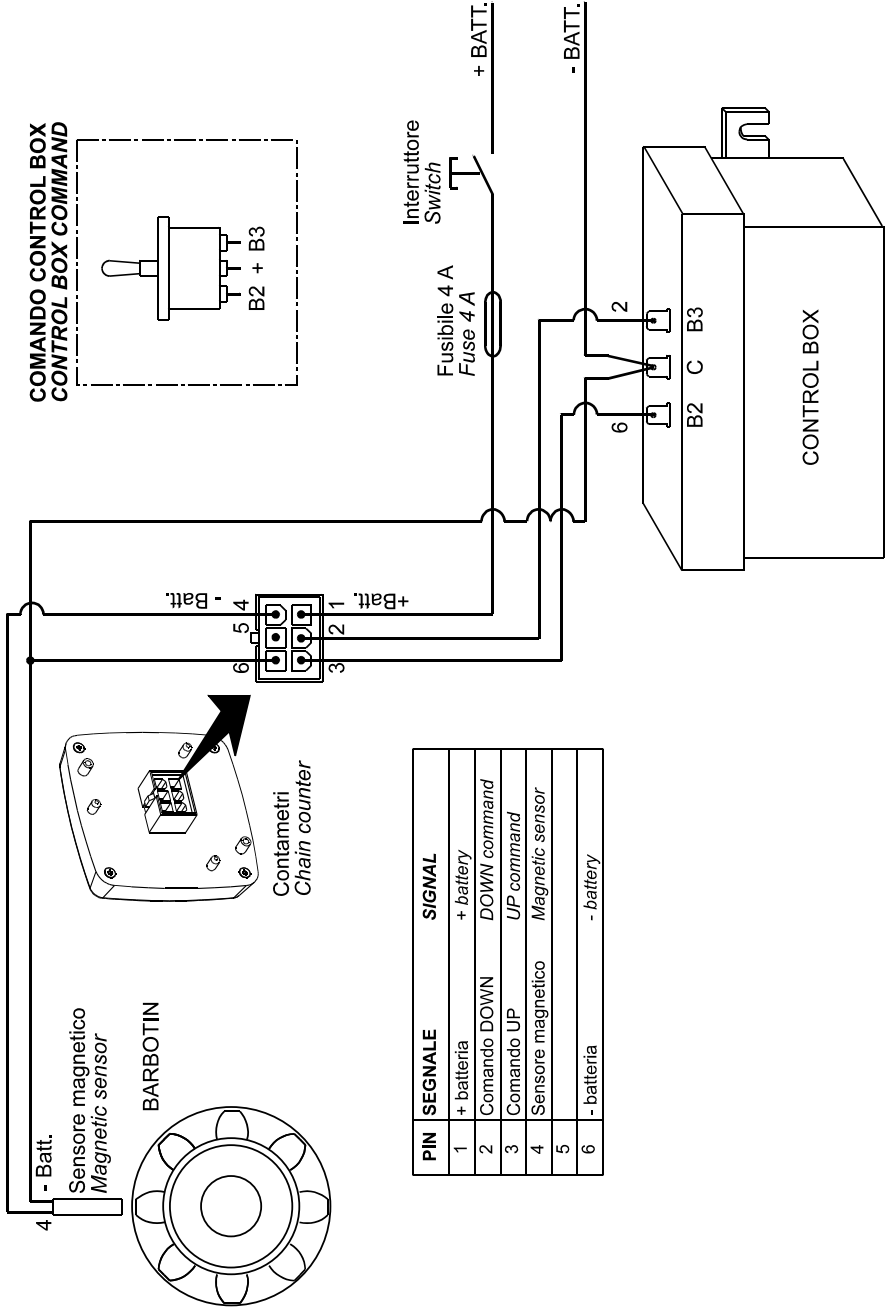

SCHEMA ELETTRICO / ELECTRICAL DRAWING

Sensore induttivo / Inductive sensor

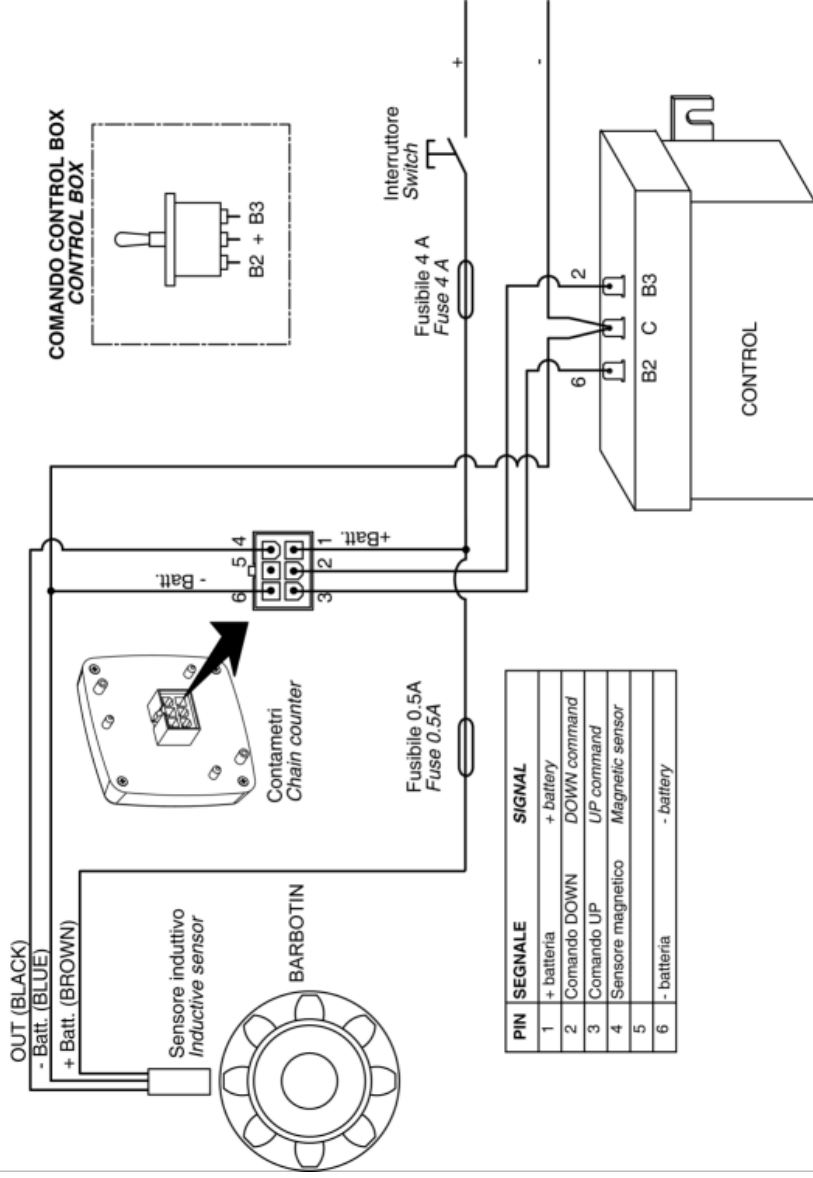

NOTA: Impostare il "Fattore di divisione" per un corretto funzionamento del sensore (vedere menu Calibrazione Sensore)

NOTE: Set the "Division Factor" parameter in order to get a correct chain length (see the "Sensor Calibration" menu)



MZ ELECTRONIC S.R.L.
www.mzelectronic.com
e-mail:info@mzelectronic.com