

MR648W MR648S

MARINIZED
MP3-COMPATIBLE CD AM/FM RECEIVER
WITH FRONT PANEL USB AND AUX INPUT

1013

BOSS® AUDIO SYSTEMS

3451 Lunar Court • Oxnard, CA 93030
www.bosssaudio.com
800.999.1236

tech support: www.bosssaudio.com/support



iPod® is a trademark of Apple, Inc.
registered in the U.S. and other countries.

USER'S MANUAL MR648W MR648S

MARINIZED
MP3-COMPATIBLE CD AM/FM RECEIVER
WITH FRONT PANEL USB PORT AND AUX INPUT



BOSS® AUDIO SYSTEMS

REMOTE CONTROL OPERATION

1. Power On/Off

2. Mute Button

3. TA Button

4. SEL/MENU Button

5&6. VOL UP/DOWN Button

7. MO/ST Button

Press the MO/ST to select stereo or mono sound mode under FM radio reception.

8. A.P Button

Press the A.P button to preview the current preset stations. (18 stations in FM) Press and hold the AP button to activate the auto storage function. The unit scans and presets the stations with the strongest signal. (18 stations in FM)

9. Band Button

10. Mode Button

11. Tune/Seek Up And Track Skip Up/FF Button

12. Tune/Seek Down And Track Skip Down/REW Button

13. SCAN BUTTON

Press the SCAN button to scan the radio frequency. If a valid signal has been detected, the current frequency will be held and blinking for 5 seconds, then press SCAN again to stop scan and remain the current frequency; otherwise, the radio will go on to scan the other radio frequency 5 seconds later.

14. CLOCK button

15. PTY Button

16. Track TOP/>||/Radio Preset 1

17. Track INT/Radio Preset 2

18. Track RPT/Radio Preset 3

19. Track RDM/Radio Preset 4

20. Radio Preset 5 and USB/CARD DIR-

21. Radio Preset 6 and USB/CARD DIR+

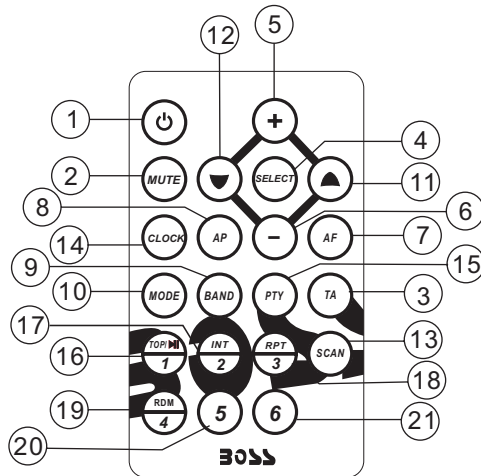

WIRING

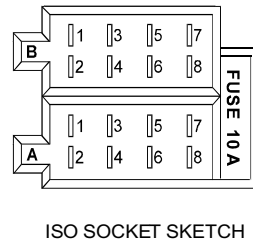
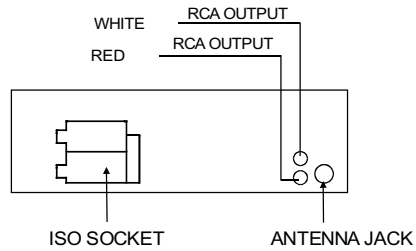

CONNECTOR A

- 1.
- 2.
- 3.
4. Memory +12V
5. Auto Antenna Output
- 6.
7. 12V (To Ignition Key)
8. GROUND

CONNECTOR B

1. Rear Right Speaker (+)
2. Rear Right Speaker (-)
3. Front Right Speaker (+)
4. Front Right Speaker (-)
5. Front Left Speaker (+)
6. Front Left Speaker (-)
7. Rear Left Speaker (+)
8. Rear Left Speaker (-)

SPECIFICATION

GENERAL

Supply Voltage	DC 12 V. Negative Ground
Current Consumption	Max.10A
Power Output	4 x 60 W
Number of channels	2 STEREO channels.
Unit Dimensions	(L x W x H): 7" x 6.5" x 1.97" 178 x 165 x 50 (mm)

FM SECTION

Frequency range	87.5Mhz - 108Mhz (Europe)	87.5 Mhz - 107.9Mhz (U.S.A.)
Effective sensitivity	3uV.	
I.F Frequency	10.7MHz.	

AM SECTION

Frequency range	522Khz - 1620Khz (Europe)	530khz - 1710Khz (U.S.A.)
Effective sensitivity	40dB.	
I.F Frequency	450KHz	

Preamp Output 1 V Output

CD PLAYER

System	MP3 Audio System.
Suitable CDs	MP3, CD, CD-R, CD-RW Disc
Frequency characteristics	20Hz-100Hz ≤ 5dB 10KHz-20KHz ≤ 5dB.
S/N Ratio to CD	50dB [1KHz]

LOCATION AND FUNCTION OF CONTROLS

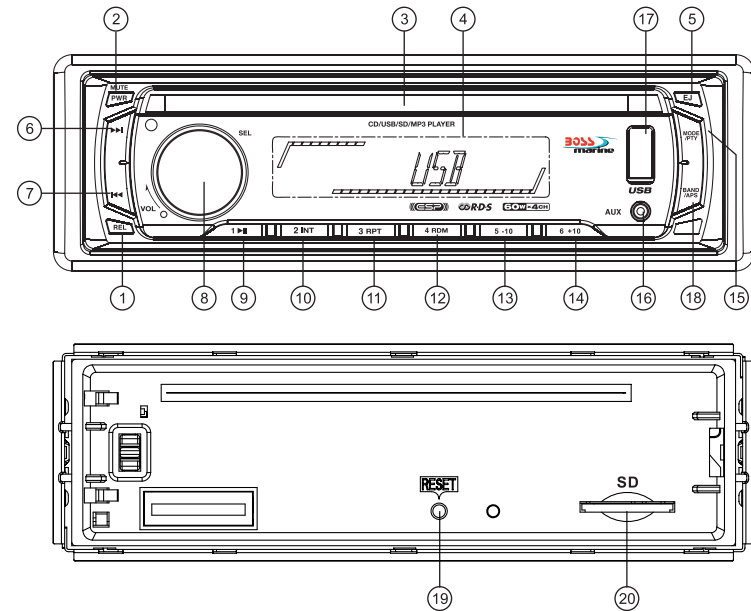

1. RELEASE BUTTON

Press the REL button to release the front control panel from the unit chassis, then pull it up a little to remove from the unit chassis.

2. POWER ON/OFF & MUTE

When the unit is power off, the unit switches on by pressing any button except the EJECT and the RELEASE button.

When the unit is power on, press and hold the power button for more than 0.5 seconds, the unit goes into power off mode.

When the unit is power on, press the power to switch the MUTE state on/off.

3. CD SLOT

4. LCD Display

5. EJECT KEY

In the power on state, the loaded disc can be ejected by pressing the EJ key.

6&7. TUNE, SEEK, TRACK, SKIP UP / DOWN BUTTONS

a) During RADIO mode:

Press the >>| or |<< button briefly to manual tune up/down for the desired radio station frequency step by step.

Press and hold the >>| or |<< button for longer 0.5 seconds, to automatically tune up/down for the radio station frequency of strong signal.

b) During disc, USB playback mode:

Press the >>| button briefly to play next track.

Press the |<< button briefly to play the current track from the beginning of it if the playing time is more than 2 seconds.

Press the |<< button briefly to play the previous track if the playing time is less than 2 seconds.

Press the >>| or |<< button and hold to skip forwards or backwards, release to resume normal playback.

8. SEL(MENU) BUTTON AND VOLUME UP (+)/ DN (-) KONB

a) Press the SEL button briefly, it is activated as selecting each mode of E. VOL.

-> VOLUME ->BASS ->TREBLE -> BALANCE -> FADER ->

When selecting a desired audio mode, rotate the VOL knob to adjust the audio effect.

In each mode, the waiting time is about 5 seconds, and when the waiting time is over, it returns to the last display mode of tuner or CD mode.

The control mode of E.VOL is operated with following numeric display.

- VOL: (MIN)00, 01,.....46, 47(MAX).

- BASS / TRE : -7, -6,....,0,....+6,+7

- LIR: (<)I,I,....,I,....,I,I(>)

- FIR: (<) I, I, . . . ,I,....,I,I(>)

b) When pressed long than 2 seconds, it will display the time, then becomes a cycling mode for the following functions for the user's selection.

->TA(ON/OFF) -> AF(ON/OFF) -> TA (ALARM/SEEK) ->PI (SOUND/MUTE)

->RETUNE (LONG/SHORT)->MASK(DPI/ALL) ->BEEP (ON/OFF)

-> USER SET(FLAT/CLASSIC/ROCK/POP)->VOL(LAST/DEFA)

-> EUROPE/AMERICA(in radio mode) ->MONO/STEREO(only for FM mode)

->LOUD(ON/OFF) ->LOCAL/DX(only for FM mode) ->CLK(ON/OFF)

->CLK(12/24)mode->CLK 00'00(you can adjust HOUR or MINUTE by rotating the VOL knob).

After selecting the desired mode, rotate the VOL knob to select one setup item of the desired mode.

1) TA [TRAFFIC ANNOUNCEMENT]

When TA mode is on(TA is displayed on LCD), it will begin to seek TA station and TA SEEK will be displayed on LCD for a while.

When traffic announcement is transmitted:

(1)If the unit is in USB or disc mode, it will switch to radio mode temporarily.

Temporarily switch over to an EON linked station when EON detects a traffic announcement on that other program, and TP will be displayed on LCD

(2)If volume level is below 20, volume level is raised to 20, and returns to its previous mode and volume level when the traffic announcement is over.

(3)If volume is adjusted during traffic announcement, only the traffic announcement volume is valid.

* TA interruption function:

The current traffic announcement is cancelled by pressing this key. But the TA mode will not be off.

* When TA is on, SEEK, (SCAN), AUTO MEMORY function can be received or saved only when traffic program identification code has been received.

DISC CARE

About CD-R/CD-R/W discs:

In addition to commercially-recorded audio CD's, this unit can play CD-R and CD-R/W discs. In some cases, particularly when recorded on older CD burners, some CD-R and CD-R/W discs may not play. Also, whenever you are recording a CD for playback in this receiver, it is recommended that you record at 24x or slower speed for CD-R and 4x or slower for CD-R/W to achieve higher signal quality and better playback performance.

1. To keep the disc clean:

Do not attach any sticker or adhesive tape on the disc.

Handle the disc by its edge to keep the disc clean and do not touch the surface.

Before playing a disc, wipe it off with a clean, dust-free cleaning cloth.

Wipe the disc outwards from the disc center.

2. When one has already been inserted. Doing so may damage the unit. Insert a disc with labeled surface up, or it will damage the unit.

3. Do not expose the disc to direct sunlight or nearby heat sources such as heating vents, caliduct which can cause the disc to warp.

Do not leave disc in a car if it is parked in direct sunlight as that will lead to a considerable rise in the temperature inside the car.

4. Do not use any secondhand or rented disc, usually, there is glue on the surface of those discs, it will stop the unit working and damage it.

5. Always store the disc in its case for protection. Scratched up discs will produce poor sound performance and cause CD player to skip.

6. In raining day or wet area, the moisture may form on the disc or the optical parts, the playback may not be possible. If moisture forms on the disc, wipe it off with a soft cloth.

If moisture forms on the optical parts of the unit, allow the unit to sit for about one hour with power on.

7. Do not use solvents such as benzine or thinners. Commercially available cleaners or anti-static spray will damage the unit.

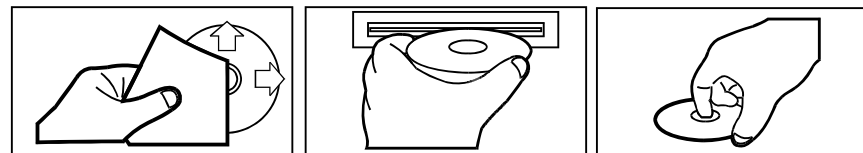

20. SD CARD SLOT

When you need to play the file in the SD card, insert the SD card into the SD card slot, the system will change into the SD mode automatically, and then play the first file in the SD.

Note:

When SD card and USB stick are both inserted into their slot or socket, the system will change into the playback mode of the latter one.

INSTALLATION METHOD

This is an anti-theft installation method.

The main unit wears a METAL MOUNTING SLEEVE.

Please connect the wiring, eg, the Power Supply, the Speakers and the Antenna according to the requirements of this Instruction Manual, then install the metal mounting sleeve into the car as per the diagram illustrated below.

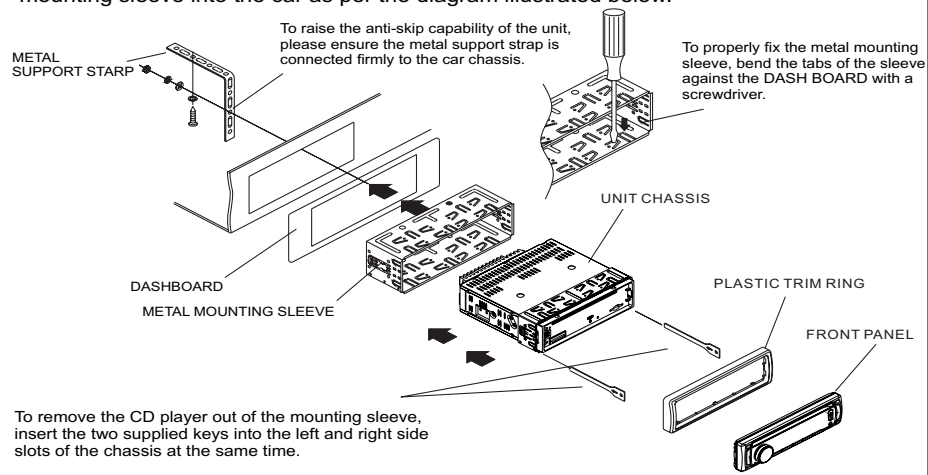

To remove the CD player out of the mounting sleeve, insert the two supplied keys into the left and right side slots of the chassis at the same time.

NOTE

Before mounting and operating the player, remove the metal mounting sleeve illustrated by the arrows.

Remove the two screws that protect the CD player during transportation before operating the player.

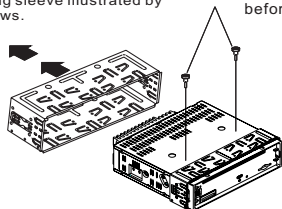

To attach the removable faceplate, insert the right side of the faceplate into the right of the CD player chassis first. Then push the left side of the faceplate into the chassis until you hear it "click".

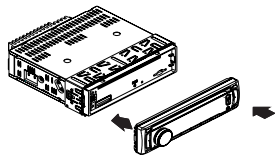

2) AF [ALTERNATIVE FREQUENCIES]

When AF switching mode is selected and the state of AF switching mode is displayed by AF segment in display.

Segment off: AF switching mode off.

Segment on: AF switching mode on, and has RDS information.

Segment flashing: AF switching mode on, but RDS information is not received yet.

When AF switching mode is selected, the radio checks the signal strength of AF all the time. The interval of checking time of each AFs depends on the signal strength of current station, from a few minute for strong station to a few seconds for weak station. Every time that new AF is stronger than current station, it switches over to that frequency for very short time, and NEW FREQUENCY is displayed for 1-2 seconds. Because the mute time of AF switching or checking time is very short, it is almost inaudible in case of normal program.

During FM mode, when AF is on, SEEK, (SCAN), AUTO-MEMORY function can only receive and save RDS program.

3) TA SEEK/TA ALARM:

TA SEEK mode: when newly tuned station does not receive TP information for 5 seconds, the radio retunes to next station which has a different PI to the last station, but has the TP information.

When TP information gets lost at the current station for retune time which is set by RETUNE SHORT(60 seconds) or RETUNE LONG(90 seconds), the radio starts to retune to next same PI station. When same PI station does not receive in 1 cyclic search, the radio retunes to next station with TP information.

TA ALARM mode: when this mode is selected, any automatic retune mode is not activated. Only double beep sound(ALARM) will be heard. When newly tuned station does not have TP information for 5 seconds, beeps are sounded.

When TP information gets lost at the current station for retune time, the beep sound will be heard.

When newly tuned station has no RDS signal, PI SEEK is suppressed.

4) PI SOUND/ PI MUTE:

PI SOUND mode: if a car cruises between buildings that could cause reflecting signals, a phenomenon may occur, due to different PI codes being received from the same AF source. when different PI sounds (DIP) are heard occasionally, this will happen for less than 1 second.

PI MUTE mode: under above same situation, a mute sound will be heard for less than 1 second.

5) RETUNE L / RETUNE S:

The initial time of automatic TA search or PI SEARCH mode is selected.

When PI information is not received for retune interval, the radio starts to retune to next same PI station.

When same PI station does not receive 1 cyclic search, the radio goes to last station and waits for 4-5 minutes until PI code is received.

RETUNE L mode: selected as 90 seconds.

RETUNE S mode: selected as 60 seconds.

6) MASK DPI/MASK ALL:

MASK DPI mode: masks only the AF which has different PI.

MASK ALL mode: masks the AF which has different PI and NO RDS signal with high field strength.

7) BEEP ON/BEEP OFF

BEEP ON mode: The beep is generated when any key is pressed.

BEEP OFF mode: The beep sound is disabled.

8) VOL LAST/VOL DEFA

VOL LAST: The radio switches on at the actual volume it had when it was last switched off.

VOL DEFA: After pressing SEL button, AVOL will be displayed. Then you can pre-select a constant switch-on volume by using the VOL knob.

9) CLK ON/OFF

CLK ON: Clock will always show on the display when power off.

CLK OFF: Clock will disappear on the display when power off.

9-14. PRESET STATION MEMORY AND TOP/>||, INT, RPT, RDM BUTTONS

a) During radio mode:

Go to any preset station by pressing one of the 6 preset station buttons (1-6).

If one of these buttons is pressed for more than 2 seconds, the station currently being listened to will be memorized into the selected preset button.

b) During disc, SD or USB mode:

1) Press the TOP/>|| button briefly to interrupt the playback of the disc, SD or USB. Press again to resume normal playback of the disc, SD or USB.

Press the TOP/>|| button and hold for approximately 0.5 seconds to play the first track of the disc, SD or USB.

2) Press the INT button to sample the first 10 seconds part of each track, and the INT ON will be visible on the LCD display.

In the process of INT, press INT button again to stop sampling and to continue playing the current track, and the LCD will display INT OFF.

3) Press the RPT button once to play the current track repeatedly, and the RPT ONE will be visible on the LCD display.

During MP3/WMA disc, SD or USB mode, press the RPT button twice continuously to play the current folder repeatedly, and the RPT DIR will be visible on the LCD display.

In the process of RPT, press RPT button again to stop playing repeatedly mode and the LCD will display RPT OFF.

4) Press the RDM button to play all tracks on disc in random order, and the RDM ON will be visible on the LCD display.

In the process of RDM, press RDM button again to stop playing in random order and the LCD will display RDM OFF.

5) Press the 5 and 6 button to move up and down 10 tracks at a time.

When the remaining total tracks are less than 10, both buttons are inactive.

Press and hold the 5 and 6 button to select next or previous folder to be played.

15. MODE AND PTY (PROGRAMTYPE) BUTTON

Press the MODE button to change among tuner (radio), disc (when a disc is loaded), USB (when an USB stick is inserted) and AUX mode.

In Radio mode, Press MODE/PTY button longer to select one of the following mode: POP M--NEWS

While selecting PTY TYPE, its selection is implemented by preset buttons as described in preset key. (press one of the 6 preset buttons shortly and repeatedly to select the PTY TYPE in the preset button)

When POP M or NEWS is on, the previous PTY program and PTY word is displayed on LCD.

If there are no keys entered for 2 seconds, previously selected PTY is searched. During 1 loop, if desired PTY is not found, NO PTY is flashed, then return to previous normal radio and PTY icon goes off.

16. AUX INPUT JACK

Press the mode button to select auxiliary input playing mode. Then you can connect any matched external audio device to this socket. Use the volume knob to adjust volume.

17. USB SOCKET

In order to play the file in the USB stick, turn over the plastic cover cap then insert the USB stick into the USB socket. The system will change into the USB mode automatically, and then play the first file in the USB.

18. BAND/APS BUTTON

During radio mode:

1) Press this button briefly to select the radio broadcasting band you would like to hear. The AM/FM band is toggled cyclically through the tuning bands: ->FM 1-> FM 2 -> FM 3 ->AM1(MW 1)->AM2(MW 2) ->.

2) Press and hold for more than 1 second, the radio searches from the current frequency and checks the signal strength level until 6 stations are found. And then the 6 stations frequency are preset to the corresponding preset memory numbered bank. The auto-storage operation is implemented in the each selected band. When the auto-storage operation is finished, the radio execute the Preset Scan.

Note: when AF OFF, it only need to use 20s to store ; while AF ON as it needs to take time to search for RDS signal, if more radio stations, it takes more time, especially if more non-RDS radio station, more time it searches.

During MP3 file in disc, or USB mode:

Press this button to turn to TRACK SEARCH mode, the LCD will display TRK 000 and flash the biggest digit 0 that the USB stick contain. (if the number of tracks is less than 100 and more than 9, it will be TRK00)

Then rotate the VOL knob to select the number of the flashing digit from 0 ~ 9. Then press SEL button to confirm the number and flash next smaller digit 0. With the same means, select the number of the flashing digit. After finishing selecting the number of all flashing digit, press SEL button to play the track of the selected serial number.

19. RESET BUTTON

Before operating the unit for the first time, or after replacing the car battery or changing the connections. You must reset the unit.

Press the reset button with a paper clip or pen. This operation will erase the clock setting and some stored content.